

ANALYSIS OF ACCIDENTS OF THE TU-154 AIRCRAFT

Jacek F. Gieras

Abstract

There have been 114 serious accidents and incidents with hull loss involving the Tu-154 passenger and cargo aircraft since January 19, 1973 (Praga, Ruzyně) through January 1, 2011 (Surgut Airport, Khanty-Mansi Autonomous Okrug). According to the author's research, the most important statistics look as follows: 73 accidents and incidents with 3013 fatalities, 4 other occurrences (hull loss) without fatalities, 5 criminal occurrences (hull loss excluding hijackings) with 232 fatalities and 3 hijackings with 13 fatalities. Five fatal accidents resulted from criminal or military actions, several other from poor runway conditions, cargo overloading, mid-air collision, mechanical problems, running out of fuels, cargo fires, fires during refueling, pilot errors and several accidents remain unexplained. Between May 1970 and February 2013 in total of 1026 Tu-154 aircraft have been delivered to carriers. The fatalities-to-number of delivered aircraft ratio is $3013/1026 = 2.937$.

Air accidents with explosion have been highlighted and compared with explosions inside cylindrical vessels and tubes (analogy to a fuselage). Professional methods of detection of explosions have been discussed. Positive explosive evidence on metals and fabrics related to crash site, wreckage, metal parts, textiles and laboratory techniques have been summarized.

Keywords - analysis, aviation accidents, aviation incidents, explosion, fatalities, hull loss, statistics, Tu-154 aircraft.

Streszczenie

Od 19 stycznia 1973 (Praga, Ruzyně) do 1 stycznia 2011 (lotnisko Surgut, Okręg Autonomiczny Khanty-Mansi) miało miejsce 114 poważnych wypadków oraz incydentów z nienaprawialnym zniszczeniem kadłuba samolotów Tu-154, zarówno pasażerskich jak i do przewozu ładunków. Wg badań autora najbardziej ważne statystyki prezentują się następująco: 73 wypadki z 3013 ofiarami śmiertelnymi, 4 inne zdarzenia (zniszczenia kadłuba) bez ofiar śmiertelnych, 5 wypadków kryminalnych (zniszczenie kadłuba nie wliczając porwan) z 232 ofiarami śmiertelnymi oraz 3 porwania z 13 ofiarami śmiertelnymi. Na skutek działań kryminalnych lub militarynych miało miejsce 5 poważnych katastrof, kilka innych na skutek złej nawierzchni pasa startowego, przeciążenia ładunkiem, kolizji w powietrzu, problemów mechanicznych, wyczerpania paliwa, pożaru, bledu załogi oraz kilka wypadków pozostaje niewyjaśnionych. Od maja 1970 do lutego 2013 zostało dostarczonych przewoźnikom 1026 samolotów Tu-154. Stosunek liczby ofiar śmiertelnych do liczby dostarczony samolotów wynosi $3013/1026 = 2.937$.

Zaakcentowanie zostały katastrofy wywołane lub połączone z eksplozją, które porównano do eksplozji wewnątrz zbiorników cylindrycznych oraz rur (podobnych do kadłuba). Przedyskutowano fachowe metody wykrywania eksplozji. Przedstawiono w skrócie jak udowodnić eksplozję na podstawie badania pola katastrofy, wraku, części metalowych, tkanin oraz badań laboratoryjnych.

Słowa kluczowe – analiza, eksplozja, incydenty lotnicze, ofiary śmiertelne, samolot Tu-154, statystyki, wypadki lotnicze, zniszczenie kadłuba.

1. INTRODUCTION

As of January 2011, since 1973 there have been 114 serious accidents involving the Tu-154 aircraft with 71 hull losses, 30 of which did not involve fatalities. Five fatal accidents resulted from terrorist or military action, several from poor runway conditions (including one in which the airplane struck heavy vehicles on the runway), violation of safety standards, and mid-air collisions due to faulty air traffic control. Other incidents resulted from mechanical problems, running out of fuel on unscheduled routes, pilot errors, and cargo fires. Several accidents remain unexplained. According to the author, the ratio of fatalities to the number of delivered aircraft from the factory is $3013/1026 = 2,937$. On January 2, 2011, Russia's Federal Transport Oversight Agency advised airlines to stop using remaining examples of the Tu-154 (B variant) until the fatal fire accident in Surgut had been investigated [1]. Its operation in Iran, which is subject to an aircraft parts embargo, ceased in February 2011 due to a number of incidents involving that type. Almost 9% of all Tu-154 losses have occurred in Iran. The largest number of fatalities in shortest time frame was between 2006 and 2011, i.e., 199 in 2006, 168 in 2009, 98 in 2010, and 3 in 2011. Following these accidents, in March 2011 the Russian Federal Bureau of Aviation recommended a withdrawal of remaining Tu-154M aircraft from service. In December 2010, Uzbekistan Airways also declared that it will cease to operate Tu-154s from 2011.

2. ACCIDENTS WITH HULL LOSS

Accidents with hull losses taking place between 1973 and 2011 are listed in Tab. 1 to Tab. 7 [2, 3, 4, 5]. According to the Aviation Safety Network (ASN) [4] the first accident took place on February 19, 1973 at Ruzyně Airport, Prague, Czechoslovakia with 66 fatalities [5] and the last one on January 1, 2011 at Surgut Airport, Khanty-Mansi Autonomous Okrug, Russia with 3 fatalities [1, 5]. A laconic information on accident near Kiev in March 1973 (Tab. 1) is only given in two Russian sources [2]. The worst accidents took place on July 10, 1985, Tu-154B2 CCCP-85311 near Uchkuduk with 200 fatalities (Tab. 2), on October 11, 1984, Tu-154B1 CCCP-85243 at Omsk Tolmachevo Airport with 178 fatalities (Tab. 7), and on August 22, 2006, Tu-154M RA-85185 near Donetsk with 170 fatalities (Tab. 7) [2, 3, 5].

Prof. Jacek F. Gieras, PhD, DSc, FIEEE, University of Technology and Life Sciences, Department of Electrical Engineering, Bydgoszcz, Poland (e-mail: jacek.gieras@utp.edu.pl).

Tab. 1. Accidents with hull losses 1973-80 (15 accidents).

Date/Airlines	Air craft	Location	Fatalities	Brief Description (cat)
19.02.1973 Aeroflot International	Tu154 CCCP-85023	Ruzyne Prague	66/ 100	Landed 470 m short of the runway (A1)
03.1973 Aeroflot	Tu154 n.d.	near Kiev Ukraine	0/n.d.	Crashed under unexpected circumstances (A1)
07.05.1973 Aeroflot Moscow	Tu154 CCCP-85030	Vnukovo Moscow Russia	0/6	Crashed during training flight (A1)
10.07.1974 EgyptAir	Tu154 SU-AXB	near Cairo Egypt	6/6	Crashed during training flight (A1)
30.09.1975 Malev Hungarian Airlines	Tu154A HA-LCI	near Beirut Lebanon	60/60	Crashed in the sea on final approach, allegedly shot down by air to air missiles (A1)
01.06.1976 Aeroflot Internat.	Tu154A CCCP-85102	Malabo Equatorial Guinea	46/46	Crashed into a mountain on final approach (A1)
??-??-1976 Aeroflot International	Tu154 CCCP-85020	Kiev Ukraine	0/n.d.	Rough landing (A1)
02.12.1977 Balkan Bulgarian Airlines/ Libyan Arab Airlines	Tu154A LZ-BTN	Benghazi, Libya	59/165	Unable to land in dense fog, ran out of fuel while searching another airfield and crash-landed (A1)
18.02.1978 Aeroflot W. Siberia	Tu154A CCCP-85087	Tolmachevo, Novosibirsk, Russia	0/n.d.	Hard landing. Fire onboard (O1)
23.03.1978 Balkan Bulgarian	Tu154 Tu154LZ- BTB	near Damascus Syria	4/4	Crashed on final approach (A1)
19.05.1978 Aeroflot Azerbaijan	Tu154B CCCP-85169	Maksatikh Smolensk Oblast, Russia	4/134	Fuel supply mistakenly turned off, crash-landed in field (A1)
01.03.1980 Aeroflot Internat.	Tu154A CCCP-85103	Orenburg, Russia	0/161	Rough landing (A1)
07.07.1980 Aeroflot Kazakstan	Tu154B2 CCCP-85355	Alma-Ata, Russia	164/164	Crashed at take-off (A1)
07.08.1980 Tarom	Tu154B1 YR-TPH	Mauritania West Africa	1/168	Ditched 300 m short of runway (A1)
08.10.1980 Aeroflot Far East	Tu154B2 CCCP-85321	Chita, Zabaykalsky Krai, Russia	0/n.d.	Rough landing (A1)

Occurrences have been categorized in the following way: A = accident, I = incident, H = hijacking, C = criminal occurrence (sabotage, shoot down), O = other occurrence (ground fire, refueling, sabotage), 1 = hull-loss, 2 = repairable damage [4]. For example, the A1 category means an accident resulting in a total loss of the plane, while C2 means a criminal (terrorist) incidents without hull loss and repairable damage. The I2 category means an incident with repairable fuselage.

The cause of the crash of Malev Tu-154A HA-LCI passenger plane on 30 September 1975 with 50 passengers and 10 crewmember into the Mediterranean, minutes before landing at Beirut airport, is unknown (Tab. 1). The weather was fine, the plane was new and in a good condition, the crew was highly experienced. Only three weeks after the crash, a brief statement consisting of little more than a couple of sentences appeared almost unnoticeably at last pages of the Hungarian dailies, which read “*The discovery, salvage, and analysis of the black box flight recorder, which may assist in establishing the cause of the catastrophe, is*

unlikely”. A detailed official statement regarding the crash has never been made. The ICAO officially has a 1 page report, which does not mention the retrieval of the bodies.

Tab. 2. Accidents with hull losses 1981-85 (6 accidents).

Date/Airlines	Air craft	Location	Fatalities	Brief description
13.06.1981 Aeroflot Moscow	Tu154 CCCP-85029	Bratsk Irkutsk Oblast Russia	0/n.d.	Overran on landing, fuselage broke into two (A1)
21.10.1981 Malev	Tu154B HA-LCF	Ruzyne Prague	0/81	Rough landing due to crew error (A1)
16.11.1981 Aeroflot Krasno- yarsk	TU154B2 CCCP-85480	Norilsk, Krasno- yarsk Krai Russia	99/167	Rough landing 470 m short of runway due to crew errors (A1)
11.10.1984 Aeroflot East Siberia	Tu154B1 CCCP-85243	Tolmachevo, Omsk, Southwest Siberia	4+174/ 179	Collided with maintenance vehicles on landing (A1)
23.12.1984 Aeroflot Krasono- yarsk	Tu154B2 CCCP-85338	Krasno- yarsk, Russia	110/111	Engine fire and hydraulics fault (A1)
10.07.1985 Aeroflot Uzbekistan	Tu154B2 CCCP-85311	Uchkuduk Uzbekis- tan	200/200	Overloaded plane stalled and crashed (A1)

Tab. 3. Accidents with hull losses 1986-90 (10 incidents).

Date/Airlines	Air craft	Location	Fatalities	Brief description
??-??-1986 Alyemda	Tu154B2 7O-ACN	Aden, Yemen	n.d.	Overran on landing (A1)
21.05.1986 Aeroflot Krasno- Yarsk	Tu154B2 CCCP-85327	Sheremetev, Moscow Russia	0/175	Deformation of fuselage during flight (A1)
18.01.1988 Aeroflot Turkmeni- stan	Tu154B1 CCCP-85254	Krasnovodsk Turkme- nistan	11/143	Rough landing, plane broke into two (A1)
08.03.1988 Aeroflot East Siberia	Tu154B2 CCCP-85413	Veshchevo Karelian Isthmus Russia	9/n.d.	Hijacking (Oviechkin brothers). Blown up (H1)
24.09.1988 Aeroflot Armenia	Tu154B2 CCCP-85479	Aleppo, Syria	0/168	Broke into two on landing, was caught by wind shear (A1)
24.09.1988 Aeroflot	Tu154?? CCCP-85617	Norilsk, Krasnoyarsk Krai, Russia	0/n.d.	Rough landing, turned into training mock-up (A1)
13.01.1989 Aeroflot International	Tu154S TuCCCP- 85067	Monrovia, Liberia	0/n.d.	Aborted take-off and runway over run due to over loading (A1)
09.02.1989 Tarom	Tu154B2YR -TPJ	Bucharest, Rumania	5/5	Crashed at take-off due to engine failure (A1)
20.10.1990 Aeroflot Georgia	Tu154B1CC CP-85268	Kutaisi, Georgia	0/171	Nose gear colla- pseed due to over loading (A1)
17.11.1990 Aeroflot International	Tu154M CCCP-85664	near Velichovsky, Czech Republic	0/6	Fire on board, the plane burned out after emergency landing (A1)

Rumors persist that the plane was shot down, either because it carried arms to some Arab group, or because it was supposed to carry the members of a PLO delegation. No evidence supporting any theory has been uncovered.

In 2004, the Hungarian Parliament voted to allocate approximately 400000 Euros to a Fund with the following aim: "localization of the wreck of the aircraft and the repatriation of those on board." It is unknown if any action has been taken.

Tab. 4. Accidents with hull losses 1991-95 (20 accidents).

Date/ Airlines	Air craft	Location	Fatali- ties	Brief description
23.05.1991 Aeroflot Leningrad	Tu154B1 CCCP-85097	Pulkovo Leningrad Russia	2+13 /178	Rough landing, nosegear collapsed and plane broke into two (A1)
14.09.1991 Cubana	Tu154B2 CU-T1227	Mexico City, Mexico	0/112	Overran on landing (A1)
05.06.1992 Balkan Bulgarian	Tu154B LZ-BTD	Varna, Bulgaria	0/130	Overran on landing in heavy rain (A1)
18.06.1992 Aeroflot Uralsk	Tu154B1RA -85282	Bratsk, Irkutsk Oblast	1+0/0	Burned out during refueling (O1)
18.06.1992 Aeroflot Privolzhsk	Tu154B1 RA-85234	Bratsk, Irkutsk Oblast	0/0	Burned out in the same incident as above (O1)
20.07.1992 Aeroflot Georgia	Tu154B 4L-85222	Tbilisi, Georgia	4+24/ 24	Crashed at take-off due to over loading (A1)
01.08.1992 Ariana Afghan	YA-TAP	Kabul, Afghanistan	0/0	Destroyed in the airport by mortar fire (C1)
05.09.1992 Air Ukraine	Tu154B1 UR-85269	Kiev, Ukraine	0/147	Rough landing with left gear still retracted (A1)
13.10.1992 Aeroflot Belarus	Tu154B2 RA-85528	Vladivo-stok Russia	0/67	Unable to take-off due to over loading (A1)
05.12.1992 Aeroflot Armenia	Tu154A EK-85105	Erevan, Armenia	0/154	Overran on landing (A1)
19.01.1993 Uzbekistan/ Indian Airlines	Tu154B UK-85533	Delhi, India	0/165	Rough landing due to crew error (A1)
08.02.1993 Iran Air Tours	Tu154M EP-ITD	near Tehran, Iran	2+131/ 131	Mid-air collision with Iranian Air Force Su- 24 (A1)
22.09.1993 Transair Georgia	Tu154B 4L-85163	Sukhumi, Abkhazia, Georgia	108 /132	Shot down by missile (C1)
23.09.1993 Orbi Georgian	Tu154B2 4L-85359	Sukhumi, Abkhazia, Georgia	0/0	Damaged by shelling (C1)
25.12.1993 Aeroflot	Tu154B2 RA-85296	Grozny, Chechen Republic,	0/172	Rough landing, nosegear collapsed (A1)
03.01.1994 Baikal Airlines	Tu154M RA-85656	Mamony Irkutsk, Russia	1+125/1 25	Engine fire at take-off, hydra-ulics failed (A1)
06.06.1994 China Northwest	Tu154M B-2610	Xian, Shaanxi Province, China	160/160	Disintegrated in mid- air due to wrong auto- pilot settings (A1)
30.11.1994 Armenian Airlines	Tu154	Grozny Chechen Republic	0/n.d.	(O1)
21.01.1995 Kazakhstan Airlines	Tu154B2 UP-85455	Karachi, Pakistan	0/117	Unable to take-off due to overloading (A1)
07.12.1995 Khabarovsk United Airlines	Tu154B RA-85164	near Gro- ssevichi, Khabar- ovsk Krai, Russia	98/98	Asymmetrical fuel supply from wing tanks, the plane crashed (A1)

An example of disorder, negligence and lack of responsibility is the accident at Tolmachevo Airport. Omsk, Southwest Siberia on October 11, 1984 (Tab. 2) [5]. One of the controllers had fallen asleep and thus failed to inform the approach controller about the presence of snow vehicles on the runway. On touchdown, the flight crew of the Tu-154B-1 CCCP-85243 saw the array of vehicles and attempted to turn the aircraft, but were unable to avoid the collision. The

plane crashed into the Ural truck and then 200 m down the runway crashed into the KrAZ¹ truck, igniting the 7 t of fuel in each truck and the aircraft's fuel tank (Fig. 1). The plane overturned and broke into pieces, some of which crashed into the UAZ-469² all-terrain vehicle. A catastrophic fracture of the fuel tanks caused burning fuel to leak into the fuselage, incinerating all but one passenger. The cockpit section detached and flew past the burning vehicles. It suffered no major damage, and all four crew members survived, suffering only minor injuries. Four ground maintenance crew were killed instantly inside the vehicles. One survivor in the passenger seat of the UAZ-469 caught on fire, which was extinguished.

Tab. 5. Accidents with hull losses 1995-00 (6 accidents).

Date/ Airlines	Air craft	Location	Fatali- ties	Brief description
29.08.1996 Vnukovo Airlines	Tu154M RA-85621	Longyear- byen, Norway	141 /141	Crashed in the mountain on final approach (A1)
13.09.1997 German AF	Tu154M 11+02	Namibia	24 /24	Mid-air collision with USAF C-141 (A1)
15.12.1997 Tajikistan Airlines	Tu154B1 EY-85281	Sharja, UAE	85 /86	Landed short of runway, crew error (A1)
29.08.1998 Cubana	Tu154M CU-T1264	Quito, Ecuador,	10+70/ 91	Aborted take-off, overran and caught fire (A1)
24.02.1999 China Southwest	Tu154M B-2622	Ruian, Zhejiang Province, China	61 /61	Crashed on final approach due to technical failure (A1)
04.07.2000 Malev	Tu154B2 HA-LCR	Thessaloniki, Greece	0/76	Gear-up touch down during the landing, skidded on runway, able to take off and land normally after a go-around (A1).

Tab. 6. Accidents with hull losses 2001-05 (6 accidents).

Date/ Airlines	Air craft	Location	Fatali- ties	Brief description
03.07.2001 Vladivostok Avia	Tu154M RA-85845	Burdakov- ka near Irkutsk, Russia	145 /145	Stalled and crashed on final approach (A1)
04.10.2001 Sibir Airlines	Tu154M RA-85693	near Sochi, Adler district, Black Sea, Russia	78/ 78	Mid-air destruction of unknown cause (C1)
12.02.2002 Iran Air Tours	Tu154M EP-MBS	Khorrama- bad, Iran	119 /119	Crashed on final approach (A1)
20.02.2002 Kish Air	Tu154M EP-LBX	Mashhad, Iran	0/ n.d.	Rough landing, (A1)
01.07.2002 Bashkirskie Avialinii	Tu154M RA-85816	Uberlingen Germany	2 +69/ 69	Mid-air collision with Boeing 757 of DHL Aviation (A1)
24.08.2004 Sibir Airlines	Tu154B2 RA-85556	Millerovo, Rostov Oblast, Russia	46/46	Exploded in mid-air by suicide bomber (C1)

The Tu-154M CCCP-85664 departed Basel Mulhouse Airport on November 17, 1990 (Tab. 3) with the cabin loaded with tobacco products (a cargo of cigarettes) [5]. In cruise flight, at 10600 m, a fire started in the rear of the

¹ Kremenchuk Automobile Plant, Kremenchuk, Ukraine.

² Ulyanovsk Automobile Plant, Ulyanovsk, Russia.

cabin, probably as a result of a heater in the galley that was left on. The fire could not be controlled and the cabin and cockpit filled with thick smoke. The crew initiated an emergency descent and were forced to carry out an emergency landing in a field near Velichovsky. The flaps could not be lowered so the airplane touched down on a marshy field at a speed of 370-390 km/h. It collided with a two-meter embankment of the road causing the plane to break up (Fig. 2). The flight deck broke away. There were only 6 crew members on board, all of whom survived with moderate injuries.



Fig. 1. Fatal accident of the Tu-154B-1 CCCP-85243 at Tolmachevo Airport, Omsk, Siberia on October 11, 1984.



Fig. 2. Wreckage of Tu-154M CCCP-85664 burned out near Velichkovsky, the Republic of Czech on November 11, 1990.

The Tu-154B UK-85533 operated by Indian Airlines on lease from Uzbekistan Airlines carrying 152 passengers and 13 crew members crashed in heavy fog early morning on January 19, 1993 while trying to land at New Delhi airport (Tab. 4) [3, 5]. The aircraft touched down slightly outside the right edge of the runway, collided with some fixed installations on the ground, got airborne once again and finally touched down on dry muddy ground on the right side of the runway. At this stage the right wing and the tail of the aircraft broke away and it came to rest upside down (Fig. 3). During the process, the aircraft caught fire and was destroyed. There were no fatalities and most occupants of the aircraft escaped unhurt.

An example of mechanical problems and negligence of crew is Cubana Flight 389 Tu-154M CU-T1264 from Quito, Ecuador to Havana, Cuba with a planned en route stop at Guayaquil (Tab. 5). A pneumatic valve during the first engine start was blocked [5]. The problem was rectified and two engines were started with ground power unit (GPU), while the third one was started as the Tu-154M taxied to the runway. When the aircraft accelerated down the runway and

reached the rotation speed³ VR, it would not rotate. With 800 m of runway length remaining the crew decided to abort the take-off. The Tu-154M overshot the runway and plowed into a soccer field (Fig. 4). It is presumed that the checklist for taxiing was not complied with and the crew forgot to select the switches for the hydraulic valves of the control system.

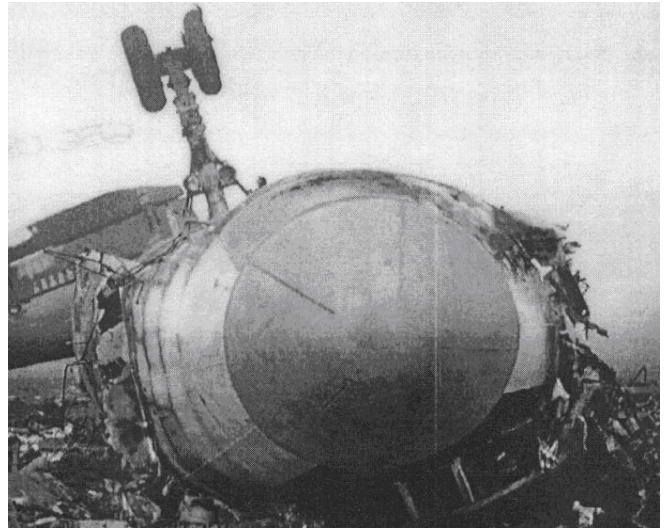

Fig. 3. Wreckage of the Tu-154B UK-85533 at New Delhi Airport on January 19, 1993.



Fig. 4. Tail section of the Tu-154M CU-T1264 at Quito-Mariscal Sucre Airport on August 29, 1998.

A mid-air collision of the Tu-154M RA-85816 of Bashkirskie Avialinii with Boeing 757 cargo plane took place on July 1, 2002 above Uberlingen, near Lake Constance (Bodensee), Germany (Tab. 6) [3, 5, 6]. Just prior to the collision, both crews detected the other aircraft, and reacted to avoid the collision by attempting appropriate flight maneuvers. The tail fin of the B-757 struck the left side of the Tu-154M fuselage near both over-wing emergency exits, while the Tu-154M left wing sheared off 80% of the B-757 tail fin. The Tu-154M immediately broke up in four pieces (left wing, right wing, main fuselage shown in Fig. 5 and tail unit including the engines) [6]. The B-757 lost control and crashed 8 km north of the Tu-154M, just after losing both engines. All 9 crew members and 60 passengers of the Tu-154M and 2 crew members of B-757 (there were no passengers) were killed.

³ The speed of an aircraft at which the pilot initiates rotation to obtain the scheduled takeoff performance.



Fig. 5. The forward fuselage section of the Tu154M RA-85816 (Überlingen mid air collision July 1, 2002) found at apple plantation near Brachenreuthe (Lake Constance) [6].

Tab. 7. Accidents with hull losses 2006-11 (8 accidents).

Date/ Airlines	Air craft	Location	Fatali- ties	Brief description
22.08.2006 Pulkovo Airlines	Tu154M RA-85185	near Donetsk, Ukraine	170/ 170	Attempt to fly over storm front at critical altitude. Stalled and crashed (A1)
01.09.2006 Iran Air Tours	Tu154M EP-MCF	Mashhad, Iran	29/ 147	The tire blew out on landing. The plane caught fire (A1)
30.06.2008 Aeroflot	Tu154M RA-85667	St Petersburg Russia	0/112	Engine fire at take-off, aborted take off (A1)
15.07.2009 Caspian Airlines	Tu154M EP-CPG	near Qazvin, Iran	168/ 168	The plane lost control. Engine fire and explosion on impact (A1)
24.01.2010 Kolavia (Taban Air)	Tu154M RA-85787	Mashhad, Iran	0/170	Rough landing, the plane broke up and caught fire (A1)
10.04.2010 Polish Air Force	Tu154M Lux PLF 101	Smolensk, Smolensk Oblast, Russia	96/96	Crashed on final approach in thick fog on an airfield with no ILS. Possible explosion in the air (?1)
04.12.2010 Aeroflot, North Kavkaz, Civil Aviation Directorate (Dagestan)	Tu154M RA-85744	Domodedo- dovo, Moscow, Russia	2/171	Emergency landing after two engines failed shortly after take-off. Overran the runway and broke up into three. Mistakenly switched off a fuel transfer pump (A1)
01.01.2011 Kolavia	Tu154B2 RA-85588	Surgut Khanty- Mansi Okrug Russia	3/124	Electric arc fire onboard while taxiing for take-off, all three engines running (A1)



Fig. 6. The Tu-154M RA-85744 with its fuselage broken into three pieces at Domodedovo airport on December 4, 2010 [7].

Even very serious damage to the fuselage not necessarily means large number of fatalities. The Tu-154M RA-85744 departing Moscow Vnukovo Airport on December 4, 2010 (Tab. 7) at a distance of about 80 km from Moscow Domodedovo Airport and at an altitude of 9000 m got fire on engines nr 1 and 3 [5, 7]. The crew decided to divert to Moscow Domodedovo Airport for an emergency landing.

The Tu-154M landed hard and struck a small earthen mound, causing the fuselage to split into three parts (Fig. 6). The crash caused the death to only two people and the injury to 86 people out of 163 passengers and 8 crew members [5].

3. INCIDENTS WITHOUT HULL LOSS

Incidents without hull losses taking place between 1978 and 2011 are listed in Tab. 8 to Tab. 13 [2-5]. According to the author's research the first recorded incident took place on November 14, 1978 at Arlanda Airport, Stockholm, Sweden with no fatalities and the last one on July 27, 2011 at Ataturk Airport, Istanbul, Turkey, also with no fatalities. About 70% of incident were caused by hijackings.

Tab. 8. Incidents without hull loss 1978-89 (5 incidents).

Date/ Airlines	Air craft	Location	Fatali- ties	Brief description
14.11.1978 Aeroflot Internat.	Tu154B1 CCCP-85286	Arlanda Airport Stock-holm Sweden.	0/74	Aborted take-off with only 500 m of runway left. The plane overran the runway, struck an ILS and went down a slope (I2)
27.02.1979 Aeroflot	Tu154 ????	Arlanda Airport Stock-holm Sweden.	0/34	Flight from Oslo to Stockholm. Crew members took control over hijackers and plane made scheduled landing (H2)
30.06.1979 CAAK North Korea	Tu154B P-551	Ferihegy Airport Budapest Hungary	0/70	The nose was raised without applying power. The aircraft stalled and landed hard. The right wing struck the ground (I2)
27.11.1982 Malev	Tu154B2 HA-LCA	Okecie Warsaw Poland	0/??	Flight from Warsaw to Budapest. Hijacker attempted to force the crew to fly the aircraft to West Berlin (H2)
29.03.1989 Malev	Tu154B2 HA-LCN	Frankfurt Germany	0/116	Flight route Budapest – Prague – Amsterdam. Two teenagers hijacked the plane and demanded to be taken to the USA (H2)

The Tu-154B1 CCCP-85286 (Tab. 8) scheduled from Stockholm to Moscow on November 14, 1978 had reached rotation speed VR when the captain felt firm resistance while trying to lift the nose. The crew decided to abort the take off with only about 500 m of runway left but the speed was too high to stop. The aircraft overran the runway at Stockholm Arlanda Airport, struck an ILS⁴ localizer antenna and crashed after the nose failed to lift up and stopped in an embankment side (Fig. 7) [2-5]. There were 65 passenger and 9 crew members on board [5]. Nobody was killed.

The Tu-154B P-551 passenger aircraft operated by the North Korean airline CAAK departing from Tripoli on June 30, 1979 sustained substantial damage in a landing accident at Budapest-Ferihegy Airport, Hungary (Tab. 8, Fig. 8) [5]. When the pilot realized that the aircraft would undershoot, he raised the nose without applying power. At a speed of 256 km/h the aircraft stalled and landed hard. The right landing gear collapsed and the right wing struck the ground

⁴ Instrument landing system (ILS).

causing substantial damage to the wing structure [2-5]. There were no fatalities.

Tab. 9. Incidents without hull loss in 1990 (10 incidents).

Date/ Airlines	Air craft	Location	Fatalities	Brief description
08.06.1990 Aeroflot	Tu154 ????	Stockholm Sweden	0/114	Flight route Minsk–Murmansk. One hijacker demanded to be taken to Sweden (H2)
28.06.1990 Aeroflot	Tu154 ????	Unknown location	0/??	Flight route Krasnodar – Krasnovarsk. Hijacker(s) demanded to be taken to Turkey (H2)
30.06.1990 Aeroflot	Tu154 ????	Stockholm Sweden	0/159	Flight route Lvov – Leningrad. One hijacker demanded to be taken to Sweden (H2)
05.07.1990 Aeroflot	Tu154 ????	Unknown location	0/??	Flight route Leningrad – Lvov. Hijacker(s) demanded to be taken to Sweden (H2)
10.07.1990 Aeroflot	Tu154 ????	Unknown location	0/??	Flight route Leningrad–Murmansk. Hijacker(s) demanded to be taken to France (H2)
12.07.1990 Aeroflot	Tu154 ????	Unknown location	0/??	Flight route Leningrad–Murmansk. Hijacker(s) demanded to be taken to Sweden (H2)
19.08.1990 Aeroflot	Tu154 ????	Unknown location	0/??	Flight route Neryungri – Yakutsk. Hijacker(s) demanded to be taken to Pakistan (H2)
12.11.1990 Aeroflot	Tu154 ????	Unknown location	0/??	Flight route Leningrad – Lvov. Hijacker(s) demanded to be taken to Sweden (H2)
02.12.1990 Aeroflot	Tu154 ????	Unknown location	0/??	Flight route Leningrad – Murmansk No further information available (H2).
21.12.1990 Aeroflot	Tu154 ????	Unknown location	0/??	Flight route Rostov – Nizhnevartovsk. Hijacker(s) demanded to be taken to the USA (H2)



Fig. 7. The Tu-154B1 CCCP-85286 at Stockholm Arlanda Airport on November 14, 1978.

The Tu-154M CCCP-85670 (Fig. 9) while approaching Zurich Kloten Airport on August 23, 1992 (Tab. 10) in conditions of heavy rain and turbulence abandoned the landing and a *go-around* procedure was initiated [3-5]. The aircraft lost some height and collided with a 6 m high antenna, located 650 m from the runway. The inner flaps on

the right wing were damaged substantially and the crew could only carry out a right hand turn instead of a left one as told by ATC⁵. A safe flapless landing was made with no injuries to 136 occupants and 9 crew members. The probable cause could be too late initiated *go-around* and incorrect assessment of the weather conditions by the crew.

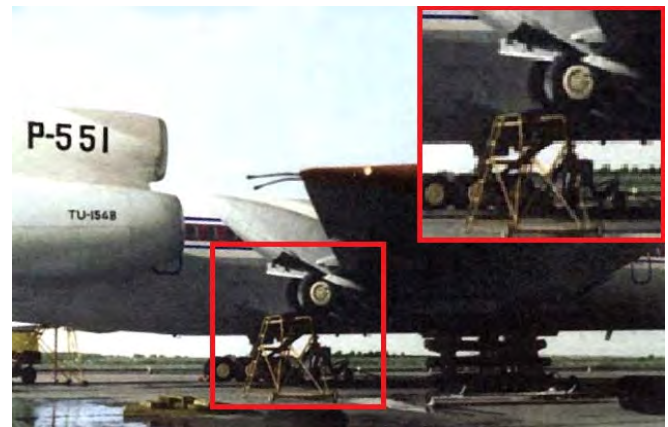

Fig. 8. The Tu-154B P-551 with damaged right landing gear and wings at Budapest-Ferihegy Airport on June 30, 1979.



Fig. 9. The Tu-154M CCCP-85670 that collided with antenna at Zurich Kloten Airport on August 23, 1992.



Fig. 10. The Tu-154M EX-85718 with damaged wing at Manas Airport, Bishkek, Kyrgyzstan on September 26, 2006.

The Tu-154 EX-85718 struck a fuel tanker KC-135R belonging to US Air Forces at Manas Airport in Bishkek, Kyrgyzstan on the night of 26 September 2006 (Tab. 13).

The American fuel tanker KC-135R *Stratotanker* with three people on board, had landed in the evening at the airport after a military mission over Afghanistan [2-5]. After landing, the KC-135R was parked at the intersection of the active runway while the crew awaited clarification on instructions from the air traffic control tower. The controller meanwhile cleared a Kyrgyzstan Airlines Tu-154 for take-

⁵ Air traffic controller.

off. The departing and accelerating aircraft's right wing passed under the outer portion of the KC-135's left wing tip, but clipped and eventually destroyed the No 1 engine (left outboard engine) and a portion of the wing. **Despite losing up to 2,5 m of its outer right startboard wing in the collision (Fig. 10 and Fig. 11), the Tu-154, with 52 passengers and nine crew, became airborne and was able to take off, reach an altitude of about 200 m and circled once before returning to the airport for a successful emergency landing.** The flight of the Tu-154M with broken wing lasted several minutes.

Tab. 10. Incidents without hull loss 1991-92 (8 incidents).

Date/Airlines	Air craft	Location	Fatalities	Brief description
21.01.1991 Aeroflot	Tu154 ????	Bourgas Bulgaria	0/159	Flight route Tashkent – Grozny – Odessa. The hijacker demanded to be taken to Istanbul (H2)
29.04.1991 Aeroflot	Tu154 ????	Moscow Russia	0/72	Flight route Barnaul – Moscow. The hijackers demanded to be flown to the USA via Germany and Iceland (H2)
13.06.1991 Aeroflot	Tu154 ????	Moscow Russia	0/111	Flight route Rostov – Moscow. The hijacker demanded to be taken to the Persian Gulf area (H2)
09.11.1991 Aeroflot	Tu154 ????	Grozny Chechen Republic	0/171	Flight route Mineralniye Vody – Ekaterinburg. The Chechen hijackers forced to land at Ankara-Esenboga Airport, Turkey. Then, the aircraft departed for Grozny (H2)
13.11.1991 Aeroflot	Tu154 ????	Skt Petersburg Russia	0/162	Flight route Irkutsk – Skt Petersburg. The hijacker demanded to be taken to the UK (H2)
29.05.1992 Ariana Afghan Airlines	Tu154M YA-TAP	Kabul Afghanistan	0/??	While descending through 200 m, the nose was struck by a missile. The aircraft landed safely (C2).
07.06.1992 Aeroflot	Tu154 ????	Vnukovo Moscow Russia	1/115	Flight route Grozny – Moscow. The hijacker demanded to be taken to Turkey. The hijacker was shot and killed (H2)
23.08.1992 Aeroflot	Tu154M CCCP-85670	Kloten Airport Zürich Switzerland	0/145	The approach to runway in heavy rain and turbulence was abandoned and a go-around initiated. The aircraft still lost some height and collided with antenna, located 650m from the runway (L2)

The accident resulted in heavy damage to both aircraft, but left no casualties and victims. The KC-135 caught fire and sustained extensive damage. US military personnel, who use Manas Bishkek international airport as a technical support base for operations in neighbouring Afghanistan, extinguished the fire without resorting to airport ground services [2-5].

Tab. 11. Incidents without hull loss 1993-95 (5 incidents).

Date/Airlines	Air craft	Location	Fatalities	Brief description
14.08.1993 Aeroflot	Tu154 ????	Sheremetevo Moscow Russia	0/??	Flight route St Petersburg – Moscow. The hijacker demanded to be taken to Sweden (H2)
01.09.1993 Aeroflot	Tu154 ????	Vladivostok Russia	0/170	Flight route Vladivostok – Ekaterinburg. A teenager sneaked onto the runway, entered the aircraft and demanded to be taken “overseas” (H2)
30.09.1993 Sichuan Airlines China	Tu154M B-2822?	Taipei Chiang Kai Shek Airport, Taiwan	0/69	Flight route Jinan – Guangzhou (P.R. China). A Chinese taxi driver hijacked the aircraft to Taiwan (H2).
27.10.1994 Unknown	Tu 154 ????	Vnukovo Moscow Russia	0/164	One hijacker demanded money. Plane was stormed and hijacker arrested (H2)
19-SEP-1995 Kish Air Iran	Tu154M	Ovda Airport Israel	0/174	Flight route Teheran – Kish Island. The hijacker demanded to fly to Europe. The plane was short on fuel and arrived in Israel (H2)



Fig. 11. Details of the damaged right wing of the Tu-154M EX-85718, which struck the parking KC-135R tanker.

The Tu-154M, RA-85684, Alrosa Mirny Air Enterprise performing flight 6R-514 from Polyarny to Moscow Domodedovo on September 7, 2010 (Tab. 13) with 72 passengers and 9 crew, was enroute at 10600 m when the aircraft about four hours after the start suffered a complete failure of electric power resulting in stoppage of fuel pumps and loss of navigation devices [5, 8]. When the plane descended under low clouds near Izhma, Komi, the commander has noticed an old airfield. The city emergency services of Izhma were advised the airplane might approach their abandoned airfield. The runway was only about 1200 m long and designed for light military aircraft, closed in 2003 and now only used as a helicopter platform. The airfield Izhma is located 3 km northeast of Izhma and 180 km north of town Usinsk. The crew was able to put the airplane down onto Izhma's abandoned runway. The impact was damped by young trees, which have grown since the airfield was closed. Because of the electric power failure, the Tu-154M could not brake on the 1200 m runway and overrun about 200 m out in the woods (Fig. 12). Although the flaps are driven by hydraulics, the flap control switches are electric. The airplane received substantial damage, but none of 72 passengers and 9 crew members suffered any

injuries [5, 8]. The crew said that it was a miracle that they could land safely on this short runway with fuel remains for 10 min only.

Tab. 12. Incidents without hull loss 1996-2000 (7 incidents).

Date/Airlines	Air craft	Location	Fatalities	Brief description
26.03.1996 Iran Air Tours	Tu154M ????	Unknown location in Iran	0/178	Ran off the right side of the runway and struck the concrete edge of a roadway. The nose gear collapsed (I2).
03.09.1996 Balkan Bulgarian Airlines, (Hemus Air)	Tu154 EP-ITS	Gardermoen Airport Oslo Norway	0/158	Flight route Beirut – Varna. A Palestinian male demanded to be taken to Norway. The plane landed at Varna Airport (Bulgaria), was refueled and took off for Oslo (H2)..
17.10.1996 Aeroflot	Tu154 ????	Murtala Muhammed Airport Lagos Nigeria	0/180	Flight route Malta – Lagos. During a stopover at Malta the plane was hijacked and demanded to be flown to Germany or South Africa (H2).
09.08.1998 East Line Airlines Russia	Tu154 ?????	Domodovo Moscow Russia	0/97	Flight route Tyumen – Moscow. A flight attendant found an anonymous note demanding money and fuel. Otherwise the plane would be blown up (H2).
??.06.1999 Probably Chinese operator	Tu154M RA-85795	Chengdu Sichuan Province China	0/??	Damaged in hard landing (I2).
18.08.2000 Azerbaijan Airlines	Tu154 ????	Unknown, between Nakhichevan and Baku, Azerbaijan	0/164	Flight from Nakhichevan to Baku (Azerbaijan). One hijacker demanded to be taken to Turkey (H2).
11.11.2000 Vnukovo Airlines	Tu154 ????	Baku, Azerbaijan Uvda Air Force Base Israel	0/59	Flight from Makhachkala (Caspian Sea) to Moscow. One hijacker demanded to be taken to Israel (H2).



Fig. 12. Emergency landing of the Tu-154M RA-85684 at old airfield in Izhma, Komi Republic, Russia, Sept. 7, 2010 [8].

According to investigations, this incident occurred as a result of the failure of the power supply 27 V DC due to thermal damage, i.e., thermal runaway⁶ of the on-board

⁶ Thermal runaway occurs when the internal heat generated during charging exceeds the rate at which the heat can be dissipated through the battery case into the environment.

20NKBN-25 nickel-cadmium battery No 1 (Fig. 13) supplying the left DC grid [8, 9, 10,]. It has been found that batteries were used in violation of the maintenance manual. Similar problems were encountered on the Boeing 787 *Dreamliner* flights in Japan and Boston in January 2013 when the lithium-ion batteries got overheating.

Overheated 20NKBN-25 batteries of the Tu-154M RA-85684 failed taking out the entire electric system and caused the failure of all attached systems including navigation and radio equipment as well as all fuel pumps.

Tab. 13. Incidents without hull loss 2001-11 (8 incidents).

Date/Airlines	Air craft	Location	Fatalities	Brief description
15.03.2001 Vnukovo Airlines	Tu154M RA-85619	Madinah M. Bin Abdulaziz Airport Saudi Arabia	3/ 174	Flight from Istanbul to Moscow. Three Chechen hijackers forced the crew to fly to Medina (H2).
05.09.2001 Uzbekistan Airways	Tu154M UK-85776	Ufa Airport Russia	0/ 116	Gear retraction problems, after takeoff from Ufa, forced to return to Ufa. On landing the right hand main gear collapsed (I2).
01.08.2003 Avialinii 400	Tu154M RA-85847	Faro Portugal	0/ 151	Overloaded plane hit trees after taking off. Flight with damaged fuselage and wings was continued to Moscow (I2).
15.08.2006 Air Koryo	Tu154B2 P-561?	Sunan Airport Pyongyang North Korea	0/ ???	During landing rollout the airplane exited the runway reportedly coming to rest against radar equipment (I2).
26.09.2006 Kyrgyzstan (formerly Altyn Air)	Tu154M EX-85718	Manas Airport Bishkek Kyrgyzstan	0/61	Collision of Tu154M with parked Boeing KC-135 during taking off. Emergency landing with curtailed right wing (I2)
08.05.2009 Iran Air Tours	Tu154M EP-MCR	near Mashhad Iran	0/ 169	In bad weather the fuselage sustained 1.8 g acceleration and was struck by hail stones. Diverted to Mashhad and landed normally (I2).
07.09.2010 Alosa Mirny Air Enterprise	Tu154M RA-85684	Izhma, Komi Republic Russia	0/81	Emergency landing at abandoned and remote air field after complete electrical failure (I2).
27.07.2011 Tatarstan	Tu154M RA-85799	Ataturk, Istanbul, Turkey	0/??	Collision with luggage track (I2)

The on-board batteries would be able to supply the Tu-154M aircraft with electric power for 30 minutes after the failure of all three main generators driven by turbopump engines. These 30 minutes include one attempt to start the auxiliary power unit (APU) and emergency booster fuel pumps.

4. SUMMARY OF ACCIDENTS AND INCIDENTS

Data listed in Tab. 1 to Tab. 13 have been summarized in Tab. 14 with specifications of accidents and incidents per decade [2-5].

Tab. 15 shows a breakdown of accidents and incidents, in which the Tu-154 aircraft have been involved [2-5].



Fig. 13. The damaged 20NKBN-25 battery No 1 in the battery compartment of the Tu-154M RA-85684, which landed at Izhma airfield September 7, 2010 [8].

Tab. 14. Summary of accidents and incidents of the Tu-154 aircraft from 1973 through 2011.

Years	Accidents with hull loss A1, C1, H1, O1		Incidents without hull loss I2, C2, H2, O2	
	Number	Fatalities	Number	Fatalities
1973-1980	15	410	3	0
1981-1990	16	612	12	0
1991-2000	26	1060	20	1
2001-2011	14	927	8	3
Total 1973-2011	71	3009	43	4

Tab. 15. Breakdown of accidents and incidents of the Tu-154 aircraft from 1973 through 2011.

Breakdown of accidents and incidents	Numbers
All accidents and incidents with fatalities	71+2=73
Accidents (A1+C1+Smolensk ⁷) in which all passengers died	22
Accidents with hull loss (A1+Smolensk)	61
Other occurrences with hull loss (O1)	4
Accidents with hull loss (A1) without fatalities	28
Accidents and criminal occurrence with hull loss without fatalities (A1+C1)	28+2=30
Hijackings (H1 + H2)	1+30=31
Hijackings (H1+H2) with fatalities	1+2=3
Fatalities in all hijackings (H1+H2)	9+4=13
Criminal occurrences (C1+C2)	4+1=5
Fatalities in all criminal occurrences (C1+C2)	232+0=232
Survival rate for all fatal accidents according to ANS ⁸	31.3%

Numbers of non-occupant casualties, i.e., ground personnel or occupants of other aircraft killed in each accident are given in Tab. 16.

Tab. 14 shows that the number of fatalities both in accidents and incidents is 3009+4 = 3013. According to the ASN the number of fatalities in hull-loss accidents is 2741, in criminal occurrences 232, in hijackings 13 and the number of killed non-occupants is 26 [4, 5]. According to the author, the same numbers are 2742, 232, 13, and 26, respectively. Adding numbers obtained by ASN, the total number of fatalities is 3012, while Tab. 14 shows 3013.

⁷ On the basis of official crash investigation reports, the ASN [3] classifies Smolensk air crash on April 10, 2010 as accident with hull loss A1, not as C1 or O1.

⁸ Survival rate of all occupant of the aircraft that survived an accident excluding ground personnel or occupants of other aircraft.

Tab. 16. Number of non-occupant casualties of the Tu-154 aircraft killed in accidents.

Date	Aircraft	Location	Casualties
11.10.1984	Tu-154B1 CCCP-85243	Tomachevo, Omsk	4
23.05.1991	Tu-154B1 CCCP-85097	Pulkovo, Leningrad	2
18.06.1992	Tu-154B1 RA-85282	Bratsk, Irkutsk Obl.	1
20.07.1992	Tu-154B 4L-85222	Tbilisi, Georgia	4
08.02.1993	Tu-154M EP-ITD	near Tehran, Iran	2
03.01.1994	Tu-154M RA-85656	Mamony, Irkutsk	1
29.08.1998	Tu-154M CU-T1264	Quito, Ecuador	10
01.07.2002	Tu-154M RA-85816	Uberlingen, Germany	2
Total			26

Cumulative number of the Tu-154 aircraft damaged beyond repair per year expresses the histogram given in Fig. 14 [4, 5]. Neighboring bars of the same height mean that there were no unreparable aircraft in the consecutive year.

Flight hours and cycles of the Tu-154 aircraft written off in accidents are given in Tab. 17 [11]. The average number of flight hours is 15251 and the average number of cycles (landings) is 7435. These numbers have been calculated using data listed in Tab. 17.

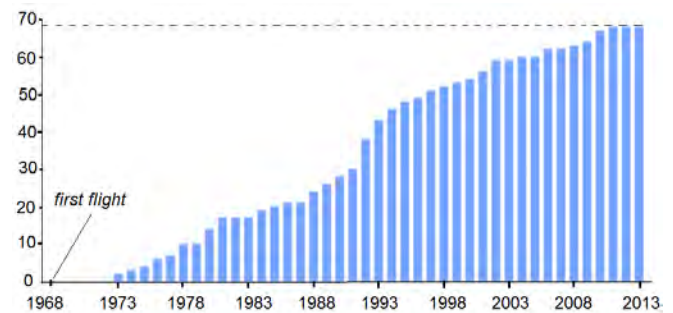

Fig. 14. Cumulative number of the Tu-154 aircraft damaged beyond repair per year according to the ASN [4, 5].

Tab. 17. Flight hours and cycles of Tu-154 aircraft written off in accidents (where known) [1, 7, 11, 12].

Aircraft	Registration	Total time since new, h	Total cycles since new
Tu-154	LZ-BTB	7800	
Tu-154A	HA-LCI	1186	
Tu-154A	LZ-BTN	3700	
Tu-154S	CCCP-85067	13 267	5949
Tu-154A	CCCP-85102	2120	1069
Tu-154A	CCCP-85103	6923	3075
Tu-154B	HA-LCF	8983	5642
Tu-154B-1	CCCP-85234	31 565	13 180
Tu-154B-1	CCCP-85268	23 472	10 227
Tu-154B-1	CCCP-85282	23 926	10 392
Tu-154B-2	CCCP-85413	11 411	4669
Tu-154B-2	HA-LCR	22 409	13 583
Tu-154B-2	RA-85556	30 751	
Tu-154M	RA-85845	20 953	11 387
Tu-154M	B-2610	12 507	6651
Tu-154M	B-2622	14 135	7748
Tu-154M	RA-85693	16 705	7281
Tu-154M	EP-MBS	12 701	5516
Tu-154M	RA-85185	24 215	
Tu-154B	RA-85588	32 354	13 147
Tu-154M	RA-85744	9288	2985
Tu-154M	PLF 101	5143	3899

5. COMPARISON OF THE TU-154 ACCIDENTS WITH THOSE OF OTHER AIRCRAFT

Comparison of the Tu-154 fatal accidents with those of selected passenger aircraft, i.e., Boeing 727, Boeing 767 and Airbus 300 is given in Tab. 18 [4]. The Boeing 727 has similar construction and parameters as the Tu-154.

Tab. 18. Comparison of fatal accidents of the Tu-154 with fatal accidents of other passenger aircraft (ASN [4, 5]).

Specifications	Tu-154	B-727	B-767	A-300
Production, total	1026	1832	1052+	561
Hull losses	71	118	14	31
Hull loss accidents	61	100	14	21
Hull loss accident fatalities	2741	3861	569	1133
Criminal occurrences (hull loss excluding hijackings)	5	3	2	5
Criminal occurrence fatalities (hull loss excluding hijackings)	232	256	0	290
Hijackings	31	178	5	25
Hijacking fatalities	13	89	282	13
Fatalities, total (occupants only)	2986	4206	851	1436
Fatalities - to - production ratio	2,91	2,2958	0,8089	2,5597
Survival rate of all occupants survived fatal accidents, %	31,3	16,1	6,1	0,6

Considering the total number of fatalities-to-production ratio, the Tu-154 is the most dangerous aircraft as compared with the B-727, B-767 and A-300. Considering the high survival rate⁹, the Tu-154 is very robust aircraft.

Cumulative numbers of the B-727, B-767 and A-300 aircraft damaged beyond repair per year are given in Fig. 15 to 17 [4, 5].

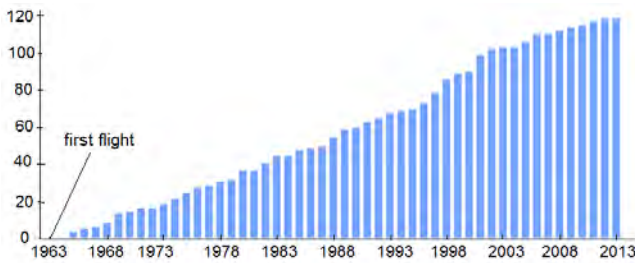

Fig. 15. Cumulative number of the Boeing 727 aircraft damaged beyond repair per year according to the ASN [4, 5].

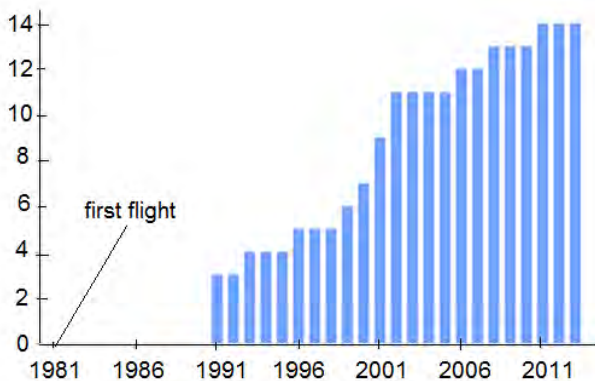

Fig. 16. Cumulative number of the Boeing 767 aircraft damaged beyond repair per year according to the ASN [4, 5].

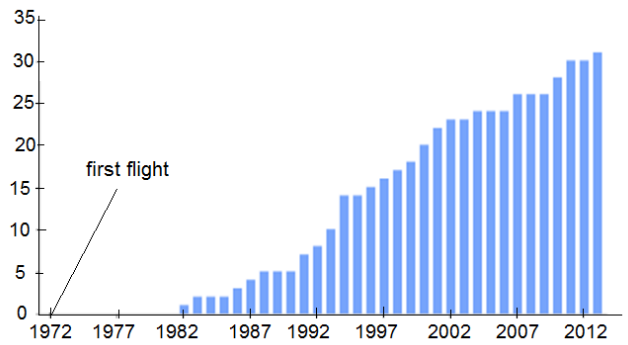

Fig. 17. Cumulative number of the Airbus 300 aircraft damaged beyond repair per year according to the ASN [4, 5].

The ASN (Tab. 18) [4, 5] estimates the total production of the Tu-154 aircraft as 1026. According to Russian archives (Appendix A), as of May 17, 2012 the number of usable and withdrawn planes is 919. Russian Register of the Tu-154 aircraft (Appendix A) estimates the cumulative production as 923 aircraft.

The highest percentage of aircraft damaged beyond repair related to their total production is for the Tu-154, i.e., $(68/1026) \times 100\% = 6,628\%$. This percentage is 6,441% for B-727, 1,33% for B-767, and 5.526% for A-300. According to the above statistics (Tab. 18 and Fig. 15, Fig. 16 and Fig. 17), the Tu-154 has experienced most hull losses in comparison with the B-727, B-767 and A-300 passenger aircraft.

6. ACCIDENTS AND INCIDENTS AS RESULTS OF BOMBING OR EXPLOSIONS

There were 3 accidents of the Tu-154 aircraft linked with proven on-ground or mid-air bombing or explosions [2-5]:

- Tu-154B2 CCCP-85413 on March 8, 1988 at Veshchevo burnt out by hijackers (Tab. 3);
- Tu-154M RA-85693 on October 4, 2001 near Sochi, Adler district (Black Sea) destroyed in mid-air (Tab. 6);
- Tu-154B2 RA-85556 on August 8, 2004 at Millerovo exploded in mid-air by a suicide bomber (Tab. 6).

The Tu-154M PLF-101 on April 10, 2010 at Smolensk North Airfield probably also exploded in mid-air due to so far unexplained reasons (Tab. 7).



Fig. 18. Destroyed tail section of the Tu-154B2 CCCP-85413 at Veshchevo air base 100 km northwest of St. Petersburg, March 8, 1988.

⁹ Percentage of all occupants survived fatal accidents related to total number of occupants of aircraft subject to accidents.

The Tu-154B2, CCCP-85413 (Tab. 3) departing from Irkutsk to Leningrad on March 8, 1988 with 170 passengers on board was hijacked by Ovechkin¹⁰ family (11 people) [2-5]. The hijackers wanted the aircraft to divert to London, but the pilots managed to convince them they would have to refuel to reach that destination. They diverted to Veshchevo, telling the hijackers this was actually an airfield in Kotka, Finland. The aircraft was stormed by Soviet security forces. A bomb exploded causing severe damage to the tail of the aircraft (Fig. 18). Five of the hijackers, 3 passengers and one female flight attendant have been killed [2-5].



Fig. 19. Remnants of the Tu-154M RA-85693 lifted by a rescue vessel.

On October 4, 2001 the Tu-154M RA-85693 of Siberia Airlines departed Tel Aviv for a scheduled flight 1812 to Novosibirsk (Tab. 6) [2-5]. It proceeded at an altitude of 11000 m at speed 850 km/h over the Black Sea.



Fig. 20. Holes found in the fuselage and other fragments of the Tu-154M RA-85693 can be identified as a shrapnel trace of anti-aircraft missiles.

At the same time the Ukraine defense forces were doing an exercise near the coastal city of Theodosia in the Crimea region. Missiles were fired from an S-200V missile battery. A 5V28 missile missed the drone¹¹ and exploded some 15 m above the Tu-154M. The aircraft sustained serious damage, resulting in a decompression of the passenger cabin and a

fire. The aircraft entered an uncontrolled descent, crashed into the Black Sea and sank to a depth of 2000 m 180 km south-west of Adler (185 km east of Sochi). Fragments of the fuselage found in the Black Sea are shown in Fig. 19 and. All 78 people on board have been killed.

On August 28, 2004 the Tu-154B2 RA-85556 operated by Siberia Airlines departed Moscow Domodedovo Airport for a scheduled passenger flight to Sochi (Tab. 6) [2-5]. About 1 h and 20 min after takeoff the aircraft disappeared from the radar. Wreckage was located several hours later near Millerovo, 138 km off the city of Rostov-on-Don (Fig. 21 to Fig. 24). All the 46 passengers and crew-members on board were killed. Traces of the explosive Hexogen (RDX) were found in the remains of the plane. Recordings from “black boxes” indicate that there was no evidence of a hijacking attempt or any other disturbance before the explosion aboard the aircraft. The subsequent investigation has found out that the bombs were triggered by two female Chechen suicide bombers.



Fig. 21. Remnants of the Tu-154B2 RA-85556 on the crash site.

At first, the experts on explosives were puzzled as they could not find any evidence of explosions in the passenger cabins or cockpit. When the tail part of the Tu-154-B2 was examined, in the area where the toilet is, an evidence of small explosion has been found. After it the tail was torn and the plain went down and collapsed into pieces. Fig. 21 to Fig. 24 show the wreckage of the Tu-154B2 on the crash site. On August 28, 2004 also the Tu-134 operated by Volga Aviaexpress was the target of the same terrorism group.



Fig. 22. Left wing of the Tu-154B2 RA-85556 on the crash site.

¹⁰ A music band called the “Seven Simeons”, consisting of seven Ovechkin brothers, aged between 8 and 26 years were considered to be celebrities of Irkutsk.

¹¹ unmanned aircraft also known as unmanned aerial vehicle (UAV).



Fig. 23. Rudder of the Tu-154B2 RA-85556 on the crash site.



Fig. 24. Turbofan engines Kuznetsov NK-8-2 of the Tu-154B2 RA-85556 on the crash site.

There are some similarities between the crash site and wreckage of the Tu-154B2 RA-85556 and the Tu-154M PLF 101 [12, 13], as for example, lack of crater, large level of fragmentation, characteristic distribution of debris, concentration of heavy parts in one place, etc.

There are symptoms that the Tu-154M PL-101 with Polish President Lech A. Kaczynski that crashed at Smolensk North Airfield on April 10, 2010 [12,13] could also be destroyed as a result of mid-air explosion [14, 15, 16, 17, 18, 19, 20, 21, 22, 23, 24, 25, 26]. The evidence of blast are photographs of the mid and rear fuselage sections taken at the crash site, i.e.:

- mid section of the fuselage with its walls split in longitudinal direction and open to the outside (Fig. 25);
- separation of the rear section of the fuselage around the frame No. 65 due to action of axial force (Fig. 26).



Fig. 25. Split skin of the fuselage (resting upside down) of the Tu-154M PLF 101 along its longitudinal axis and rolled out.



Fig. 26. Rear part of fuselage of the Tu-154M PLF 101 torn around the frame No. 65 with broken bolts.

However, using formal terminology in logic, this is a *necessary condition*, but not *sufficient condition* that the Tu-154M PLF-101 has exploded. Without detailed examination of the wreckage or/and postmortem examination of bodies of victims (autopsy), it is impossible to diagnose if the burst of the aircraft was a result of mid-air explosion. It could not necessarily be caused by an explosive material, bombing or missile. There is also a possibility of explosion of the fuel-air mixture in one or more fuel tanks [27].

7. INVESTIGATION OF MID-AIR EXPLOSIONS

7.1. Crash site

Visual inspection of the crash site and observation how the aircraft structure breaks up provides key evidence of location of explosive materials and estimation of its size [15]. Wreckage trail analysis allows for determination of break-up sequence. The first pieces of structure released from the aircraft are usually close to the epicenter of the burst [14]. Fig. 27 shows the wreckage trail plot grouped by parts of the Tu-154M PLF-101 aircraft. The heaviest parts (engines, middle and rear fuselage from the frame No 40 to 64 and from 65 to 83, rudder) are in the center of the crash site. However, it is very difficult to estimate the break-up sequence only using this satellite photograph. Supporting evidence as, for example, professional examination of the wreckage must be done. It is not true assuming that structural items found in the trail are detached in a sequence equivalent to their distance from the epicenter [14].

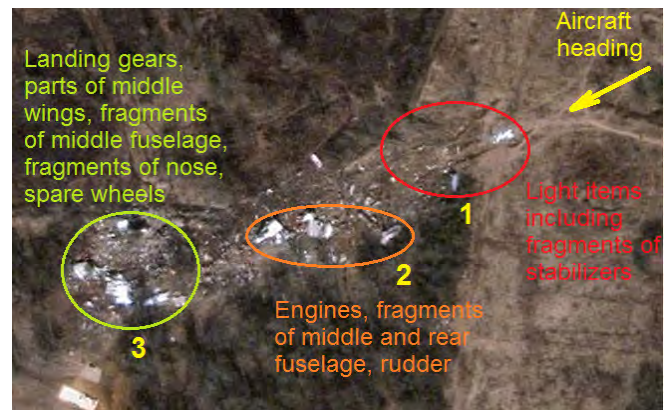

Fig. 27. The Tu-154M PLF 101 wreckage trail plot grouped by location of parts of the aircraft: (1) light items including fragments of stabilizers; (2) engines, fragments of middle and rear fuselage, rudder; (3) landing gears, parts of middle wings, fragments of middle fuselage, fragments of nose, spare wheels.

7.2. Wreckage

The fuselage is a cylindrical thin-wall structure reinforced radially by fuselage frames and longitudinally by stringers. These parts are riveted using brackets and clips.

Assuming that the pressurized fuselage is a cylindrical vessel with closed ends, **the hoop stress is double the longitudinal stress** [14]. Under explosion, its skin punctures and internal pressure causes the cracks to grow. Since the hoop stress is predominant, the fuselage is pulled apart in the radial direction and longitudinal cracks are formed along the rivet lines (weakest pathway) [14, 20, 21, 24, 28,].

Every caution must be taken when investigating the skin of the aircraft because cracks along riveting paths caused by inner burst look similar to cracks due to pressurizing and depressurizing the fuselage. **Cracks in the aluminum skin of an aircraft are commonplace**¹². The riveted joints may fail because the cabin is pressurized. At high altitude the pressure inside the cabin is the same as it is at sea level, while the outside pressure is lower. When the airplane takes off, the fuselage is pressurized and when it descends, the fuselage is depressurized. Under cyclic forces the aluminum skin undergoes fatigue (Appendix B). The longer the aircraft is in operation, the more frequently cracks begin to appear.

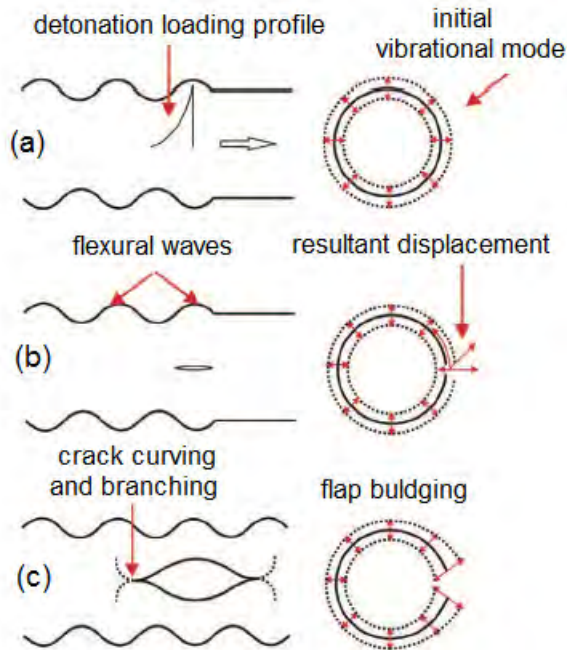

Fig. 28. Cyclic crack growth in a tube: (a) moving detonation front; (b) formation of flexural waves; (c) flap bulging, curving, and branching [20].

One of the most important questions that arouse during the accident investigation is whether the type of accidental combustion can be deduced from the fracture patterns [20]. It has been recently proved that at high pressure level a major portion of crack growth under the influence of fluctuating stresses is periodic (Fig. 28) [20]. The passage of detonation front results in a pattern of fluctuating hoop strains. Large tensile stresses develop in the bulged region in the axial direction of the tube causing a rupture of the tube (Fig. 28) [20]. Examples of confined ruptures of

experimental aluminum tubes under internal gaseous detonation are shown in Fig. 29 [28].



Fig. 29. Examples of confined ruptures of experimental aluminum tubes under internal gaseous detonation [28].



Fig. 30. Explosion of liquefied petroleum in truck tank, Xigu District of Lanzhou, Gansu Province, China on February 20, 2012. Source: http://www.china.org.cn/photos/2012-02/21/content_24689788.htm

In the case of explosion in a thin-wall cylindrical vessel, its closed ends can be also torn down. Typical example of such explosion is rupture of truck tank with liquefied petroleum on February 20, 2012 in Northern China (Fig. 30). Inner forces in longitudinal direction have torn the closed ends off the cylindrical section. Similar action of inner axial forces can be observed when the rear portion of the fuselage is separated from the mid fuselage, e.g. Fig. 26.

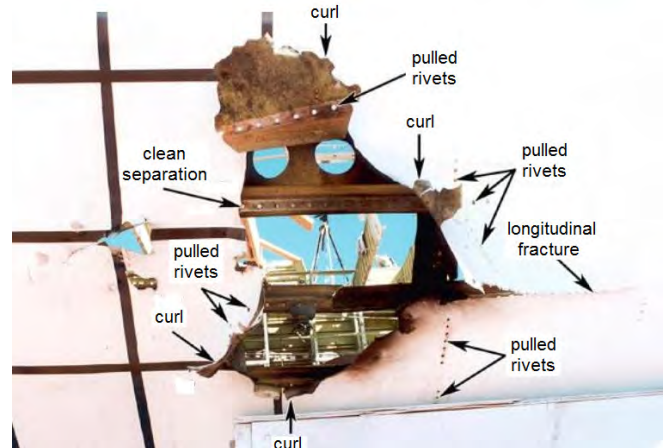

Fig. 31. Exterior view of a petaled hole in the fuselage skin of an unpressurized B-747 aircraft following the detonation of IED installed in luggage container. A longitudinal fracture originates from the hole [17].

¹² L. Greenemeier, What causes an airline fuselage to rupture mid-flight? How can this be prevented? Scientific American, April 5, 2011. <https://www.scientificamerican.com/article.cfm?id=southwest-airplane-aluminum-cracks>

An improvised explosive device (IED) usually used by terrorists, when detonated, creates a petaled hole in the fuselage skin (Fig. 31) [17]. Portion of the skin roll out and tear away from the center of the rupture, creating curls, as post-blast gases vent [17].

For detailed analysis of explosion, the 3D physical reconstruction of damaged aircraft using a supporting structure is crucial [14]. If the wreckage is not available, at least a 3D computer reconstruction should be done. Computer simulation of the structural response of a blast loaded fuselage of aircraft has been done, e.g., in [16, 19, 26, 29, 30,].

7.3. Metal parts

According to [14], an explosive signature¹³ is a feature showing a positive and unique indication that an explosive detonation has occurred in the immediate vicinity of the investigated fragment. Any other explanation violates the science, engineering and technology.



Fig. 32. Good example of explosive signature that shows pulled rivets, staining, microcraters, petaled hole, rolled edges (curl) and gas wash in the skin of an aircraft fuselage [17].



Fig. 33. Petaled hole with rolled edges in a wing part (probably wing fairing) of the Tu-154M PLF 101 found near crash site. This hole is not a full evidence of explosion because no other symptoms of explosion as, for example, tensile rivet failure, staining, impact craters, etc., are visible. Source: http://inapcache.boston.com/universal/site_graphics/blogs/bigpicture/poland_04_12/p03_22969387.jpg

¹³ A distinctive mark, characteristic, or sound indicating identity.

The size of the piece of evidence is not important because it always is a sufficient proof of explosion [14]. If there is 100% guarantee that the given piece really comes from the aircraft under investigation, only one *signature* on a single item is sufficient [14]. One signature is understood as a series of distinctive marks characteristic for explosion (Fig. 31 [17]).

As it has been mentioned, rivets in the skin not necessarily are to be broken by inner explosion. They can be broken also due to cyclic pressurizing and depressurizing the fuselage (Appendix B). However, the tensile rivet failure, distinctive shape of a hole, rolled edges, impact craters and staining taken together are definitely an explosive signature. Fig. 32 [17] shows a strong evidence of explosion, while Fig. 33 shows a partial evidence of explosion in the skin probably of a wing fairing of the Tu-154M PLF-101. A number of photographs showing skin tensile rivet failure in a small piece of the Tu-154M PLF-101 are presented in [23].

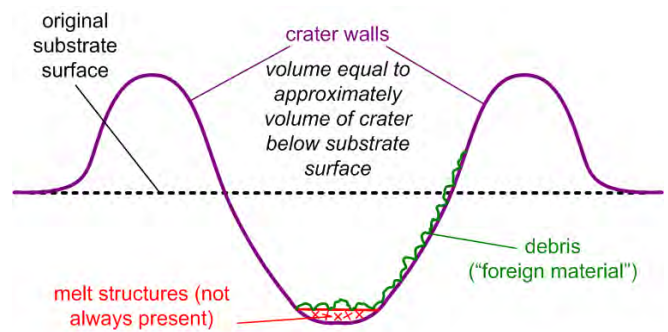

Fig. 34. Structure of impact crater created in metal parts as a result of explosion [17].



Fig. 35. Experimental explosive cladding: aluminum deposited on a copper sheet. Craters are formed explosively [14].

Positive explosive evidences on metals include but are not limited to [14, 17, 19, 24]:

- fuselage skin tensile rivet failure, crack initiation and longitudinal fracture (Fig. 31);
- petaled holes, which can be created not only by a high-energy explosive materials placed in direct contact with the sheet metal, but also by objects projected by the blast (Fig. 30 to Fig. 33);
- rolled edges that are produced as an action of hot gases at high pressure and velocity, which result in heating, softening and turning over the edges (Fig. 32 and Fig. 33);

- staining (Fig. 32);
- Gas wash, i.e., gases have a scouring action and an overall smoothing and eroding effect (Fig. 32);
- fragments originated from unburned particles, detonators and containments with sizes of 0,5 to 1,0 mm with distinctive appearance that is immediately recognizable by an experienced investigator;
- impact craters with size from a few microns up to several millimeters caused by high velocity impact of small particles (Fig. 34);
- explosive cladding – the chunks from the closer structure to explosion center impact the surface of the outer structure, thus producing craters, with residues of the chunks adhering to the crater surface (Fig. 35);
- microstructural features observed by metallographic examination (supporting evidence).

Only one evidence, e.g., petaled hole with rolled edges shown in Fig. 33 is not a sufficient evidence of explosion. Furthermore, the investigator should look for pulled rivets, staining, impact craters, gas wash and explosive cladding [14]. Two or more such of evidences constitute an explosive signature.

7.4. Fabrics

Positive explosive evidence on fabrics, such as woven material of armchairs, carpets, passenger clothes, bags, etc., includes, but is not limited to [14]:

- explosive flash melting (Fig. 36);
- globularizing of melting of the ends of fibers (Fig. 37),
- interpenetration of fabrics (Fig. 8).

The seat belt described in [22] should be examined further. Magnified photographs taken through a microscope can show or exclude the effects of explosive flash melting or globularizing of fiber ends.

7.5. Laboratory techniques

Initial laboratory examination normally includes a thorough visual inspection, photography, measurement of features of areas of interest and examination using a standard optical microscope. Further investigations use scanning electron microscopy (SEM), electron probe microanalysis (EPMA), X-ray diffraction (XRD), X-ray photoelectron spectroscopy (XPS), Fourier transform infrared spectroscopy (FTIR) and other techniques [14].

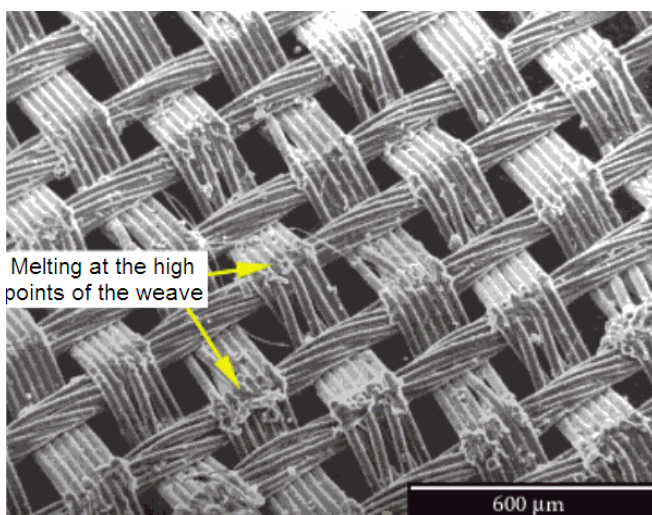

Fig. 36. Explosive flash melting on nylon [14].

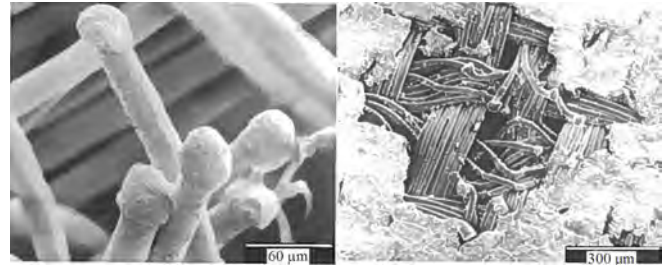

Fig. 37. Globularizing of fiber ends [14].



Fig. 38. Interpenetration of fabrics [14].

8. CONCLUSIONS

The ratio of fatalities (2986 according to the ASN, including only occupants [4,5]) to the total number of aircraft (1026) delivered to carriers is 2,91¹⁴ for the Tu-154. For comparison, the same rate for the Boeing 727 (very similar to Tu-154) is 4206/1832 = 2,2958, for the Boeing 767 is only 851/1052 = 0,8089 and for the Airbus 300 is 1436/561 = 2,5597.

According to the ASN [4, 5], the survival rate for all fatal accidents of the Tu-154 is on average 31,3% of all occupants survived fatal accidents, while for the B-727, B-767 and Airbus 300 is 16,1%, 6,1% and 0.6%, respectively.

The highest percentage of aircraft damaged beyond repair related to their total production is 6,628% for the Tu-154. This percentage is 6,441% for the B-727, 1,33% for the B-767, and 5,526% for the A-300.

The average number of flight hours of the Tu-154 aircraft written of in accidents is 15251 and the average number of cycles (landings) is 7435.

According to the statistics presented in Tab. 14 - Tab. 17 and Fig. 14 - Fig. 17, the Tu-154 is the most dangerous aircraft as compared with the B-727, B-767 and A-300 passenger aircraft.

According to modern techniques of forensic investigations into explosions [15], there is not enough evidence so far to prove that the Tu-154M PLF 101 was destroyed on April 10, 2010 by mid-air explosion. There are distinctive marks of rupture, but not sufficient [14]. Only detailed and professional examination of the wreckage, personal belongings of victims, their clothes and autopsy can confirm the explosion, i.e., detonation of explosives [15] or ignition of fuel-air mixture [27].

Cracks in the aluminum skin along riveted paths are commonplace. The riveted joints may fail because the cabin is pressurized. At high altitude the pressure inside the cabin is the same as it is at sea level, while the outside pressure is lower. When the airplane takes off, the fuselage is pressurized and when it descends, the fuselage is

¹⁴ 3013/1026 = 2,937 including non-occupants.

depressurized. Under cyclic forces the aluminum skin undergoes fatigue (Appendix B).

Further investigations on the basis of the reports [12, 13, 31] elaborated without professional examination of the wreckage, its 3D reconstruction (physical or virtual), original records from flight data recorder (FDR) and cockpit voice recorder (CVR), detection of explosives immediately after the crash, laboratory tests on specimens, and detailed post-mortem examination of bodies may induce improper image of the tragic occurrence and can even further obstruct the truth.

Smolensk was rather constantly monitored and photographed by CIA satellites, because it was one of transfer bases for Victor A. Bout, a convicted Russian arms trafficker [32], transferred in 2012 to the US Penitentiary, Marion, IL. The CIA can be in possession of valuable information and documentation, what happened at the Smolensk North Airfield on April 10, 2010.

If the tip of the left wing of the Tu-154M PLF 101 has been cut off as a result of collision with a birch tree as stated in the reports [12, 13], the outer left wing fuel tank became open. About 812 to 906 l (650 to 725 kg) of fuel Jet A-1 has been released at very low altitude leaving traces of fuel leak on the ground (Appendix C). As far as the author is aware, no investigation of fuel residuals along the flight path from the famous birch tree to the crash site has been reported.

There are still reliable evidences, which have not been manipulated:

- a) results of independent postmortem examination of bodies of all victims;
- b) the FSB¹⁵ report prepared in three hours after the tragedy, with description and sketches of four birch trees, none of which does meet the criteria of "armored birch tree" [33];
- c) the first testimony/affidavit of controllers (not the next one being dictated after the annulment of the first);
- d) Satellite images taken by US satellites on April 10, 2010, which probably have been handed over to Polish authorities;
- e) analysis of conversations recorded in a black box and a tape cassette recorder of Yak-40, which landed in Smolensk before the Tu154M PLF 101 that have been in Polish hands for over four years;
- f) detailed investigation of all events taking place before the departure of the Tu-154M PLF 101 from Warsaw-Okęcie (F. Chopin Airport) in early morning April 10, 2014;
- g) opinions and testimonies of experienced pilots.

On the other hand, the clue can also be found in the catastrophic malfunction of the aircraft power plant and propulsion system, i.e., failure of the D30-KU turbofan engines. In the past, both the IL-62 *Kopernik*, flight LO-007 from New York JFK to Warsaw-Okęcie on March 14, 1980 [34] and the IL-62 *Kosciuszko*, flight LO-5055 from New York JFK to Warsaw-Okęcie on May 9, 1987 [35] crashed due to turbofan engine failures (Appendix D). The IL-62 *Kosciuszko* was equipped with the same Soloviev D30-KU low-bypass turbofan engines as the Tu-154M PLF 101. Similar detailed engine examinations as those described in [34, 35] should be done in the case of the Tu-154M PLF 101.

¹⁵ Federalnaya Sluzhba Bezopastnosti Rossiyskoy Federatsii (Federal Security Service of the Russian Federation).

APPENDIX A. PRODUCTION STATISTICS OF TU-154 AIRCRAFT

Tu154 statistics according to Russian register of Tupolev Tu-154 aircraft are given in Tab. 189.

Tab. 19. Statistics of the Tu-154 aircraft according to <http://archive.is/Pk5G> dated May 27, 2012.

	FL	NF	ST	BU	CR	DA	BL	T
Tu154M	80	-	152	65	16	2	11	324
Tu154B2	13	-	107	196	6	6	-	322
Tu154	0	2	7	11	2	2	0	22
Tu154B1	0	0	16	108	6	1	0	130
Tu155	0	0	1	0	0	0	0	1
Tu154A	0	0	1	13	3	0	0	17
Tu154S	0	0	1	7	0	1	0	8
Tu154B	1	0	14	76	4	1	0	95
Total	94	2	299	476	37	13	11	919

The following abbreviations has been used: FL = flying, NF = not flying, ST= stored, BU = broken up, CR = crashed, DA = damaged, BL = built, T = total.

Fig. 39 shows production of the Tu-154 aircraft per year (items per year), while Fig. 40 shows the accumulative production of the Tu-154 aircraft between 1968 and 2012.

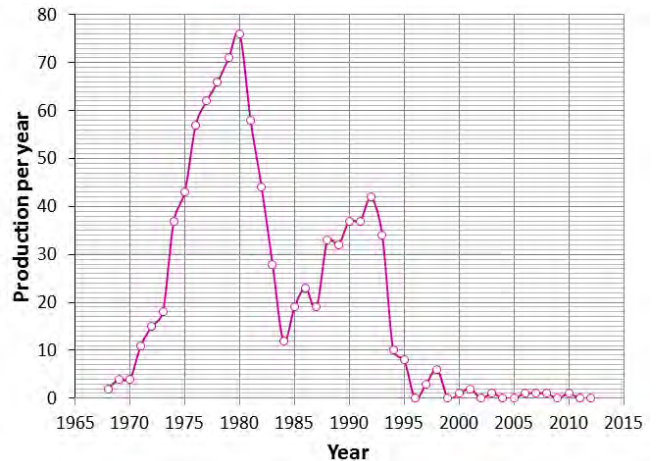

Fig. 39. Production of the Tu-154 aircraft per year according to Russian Register of the Tu-154. Plotted on the basis of data available at <http://russianplanes.net/planelist/Tupolev/Tu-154>.

According to ASN data base the total number of the Tu-154 aircraft delivered to carriers is 1026. According to Tab. 18 this number is much lower and equal to 919. Fig. 39 and Fig. 40 indicate yet different number, i.e., 923.

The first flight of the Tu-154 CCCP-85000 was held October 3, 1968. The first flight with passengers took place February 9, 1972 on the route Moscow Sheremetievo - Mineralniye Vody. On the basis of the Tu-154, a number of modifications, including alterations for non-civil operators have been implemented. These are: the Tu-154A, Tu-154B-1, Tu-154B-2, Tu-154M (passenger variants), Tu-154S (freighter) as well as a number of flying laboratories: the Tu-155 (with SU NK-88 liquid hydrogen), Tu-156 (with SU NC-89 CNG), Tu-154LL test program *Buran* aircraft to train astronauts in weightlessness, and to monitor the program *Open Skies*.

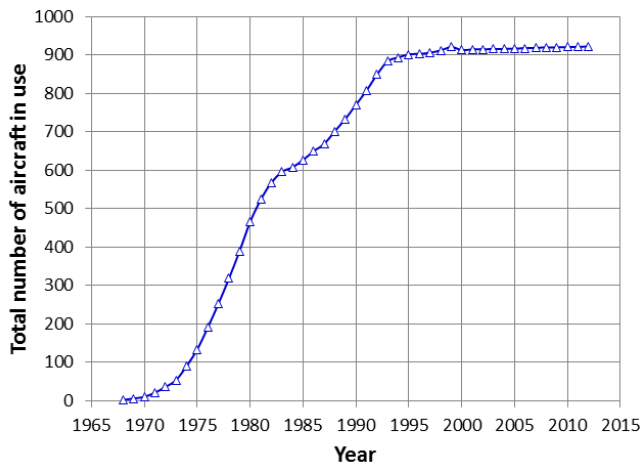

Fig. 40. Cumulative production of the Tu-154 aircraft according to Russian Register of Tu-154. Plotted on the basis of data available at <http://russianplanes.net/planelist/Tupolev/Tu-154>.

APPENDIX B. CRACKS IN THE SKIN

The cabin is periodically pressurized and depressurized at taking off and descending. Large panels of skin along the fuselage are riveted. Under cyclic forces due to pressure variation the aluminum skin undergoes fatigue. Fatigue accelerated by corrosion causes cracking problems in the lap riveted joints.



Fig. 41. Open fuselage of the Boeing 737 Aloha Airlines, Flight 243, April 28, 1988 due to cracks along riveted paths. Source: <http://deicinginnovations.com/wp-content/uploads/2012/07/Aloha.jpg>

On April 28, 1988 a 19-year old Boeing 737-200, operated by Aloha Airlines as Flight 243 lost a major portion of the upper fuselage at 7300 m while en route from Hilo, to Honolulu, Hawaii (Fig. 41). The pilot performed an emergency descent and landed at Kahului Airport on the Island of Maui. There were 89 passengers and 6 crewmembers on board. One flight attendant was swept overboard during the decompression. Multiple fatigue cracks were detected in the aircraft structure in the holes of the upper longitudinal row of rivets on several fuselage skin lap joint paths.

The rip in the roof (Fig. 42) of the 15-year old Boeing 737-300 aircraft caused rapid loss of pressure in the cabin of Southwest Flight 812 that had just taken off from Phoenix, AZ for Sacramento, CA on April 1, 2011. Pilots quickly descended from 11000 m and safely landed the damaged

aircraft at a military base near Yuma, southwest of Phoenix, AZ, USA.

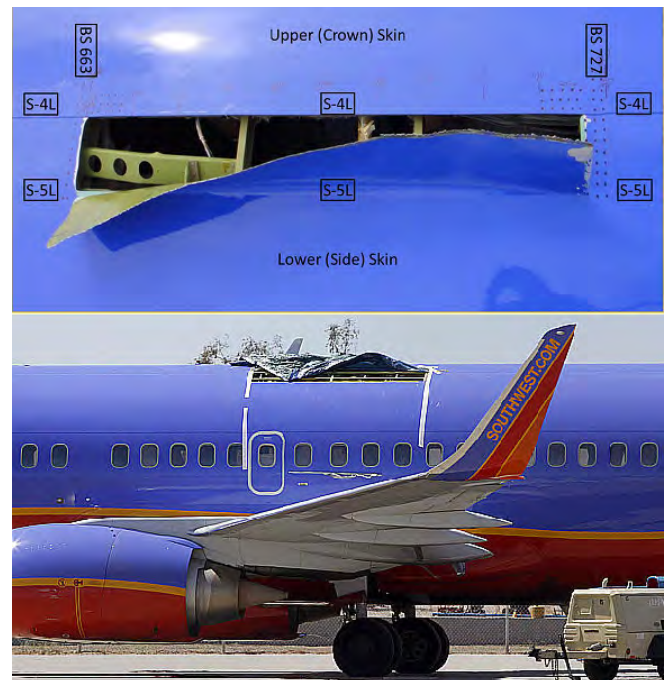

Fig. 42. Roof of the Boeing 737-300 Southwest Airlines Flight 812 with 1.5-m long rip, April 1, 2011. Source: <https://www.scientificamerican.com/article.cfm?id=southwest-airplane-aluminum-cracks>.

The investigators of the National Transportation Safety Board (NTSB) have found cracks in portions of the lap joint running on two lines of riveted paths covering the length of the fuselage of the Boeing 737-300 involved in the incident.

APPENDIX C. DAMAGE TO WING FUEL TANK

If the Tu-154M PLF 101 hit the birch tree and lost a tip of the wing on April 10, 2010, the outer wing fuel tank would rupture. Location of wing fuel tanks of the Tu-154M is shown in Fig. 43. It is estimated that shortly before the crash, approximately 650 to 725 kg of Jet A-1 fuel could be in the left wing outer tank [9]. Assuming the average fuel density at 15°C as 800 kg/m³, the volume of fuel amounted to 812 to 906 l. Such large amount certainly would leave some traces of fuel in the nearest vicinity of the tree and on the path from the collision with tree to the crash site.

Fig. 44 and Fig. 45 show the fuel leak from the damaged tip wing fuel tank of Russian Tu-154 RA-85799 aircraft operated by Tatarstan after collision with a luggage truck at Ataturk Airport in Istanbul, Turkey. The incident resulted in the wing hole, from which emerged on the tarmac more than 5 tons of fuel. It is clearly visible how intensive and massive was the fuel stream. Conditions of fuel leakage at the airport (zero speed, ground level) and at the landing approach (speed about 270 km/h) are different, but residuals and traces of Jet A-1 should be found, because the aircraft was at very low altitude (from a few meters to few dozen meters). Why this important evidence has not been investigated if the Reports [12, 13] conclude that the main cause of the crash was the lost of 6,1 m tip portion of left wing as a result of impact with birch tree?

Fuel leakage from aircraft fuel tanks requires comments. Fuel is damped from aircraft in emergency situations when the plane must return to the takeoff airport or divert to

another airport soon after takeoff. The reason is to reduce the landing mass, which depends on a particular model and, in general, is lower than the takeoff mass. As fuel is jettisoned, it is rapidly broken up into small droplets, which then vaporize. According to studies of US Air Forces

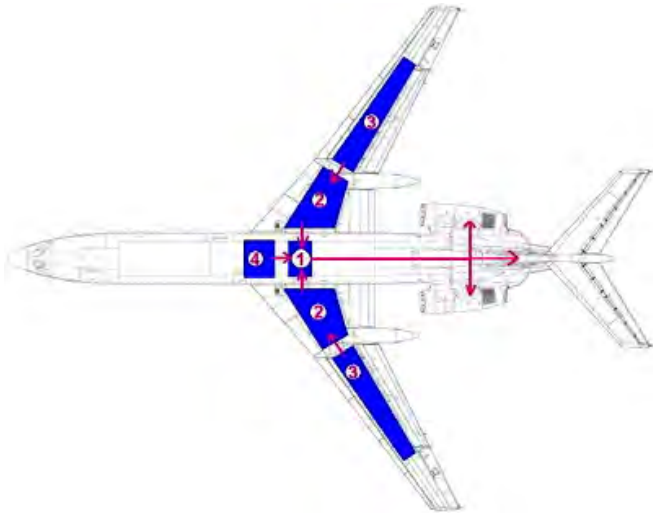

Fig. 43. Fuel tank configuration of the Tu-154M: No 1 - center wing tank (CWT), i.e., collector tank, No 2 - inner left and right wing tank, No 3 - outer left and right wing tank, No 4 - additional tank.



Fig. 44. Tu-154M RA-85799 and luggage truck after collision at Istanbul Ataturk airport on July 27, 2011. Source: <http://www.euromag.ru/turkey/11679.html>.



Fig. 45. Fuel leakage from the damage tip wing of the Tu-154M RA-85799 at Istanbul Ataturk airport on July 27, 2011. Source: <http://www.euromag.ru/turkey/11679.html>

(USAF) [36] fuel jettisoned above 1500 to 1800 m will completely vaporize before reaching the ground. The outside air temperature is very important factor. Fig. 46 shows the percent of fuel mass JP-4 reaching the ground as a

function of dump altitude for variety of air temperatures. To the author's best knowledge, similar graphs for the fuel Jet A-1 are not available.

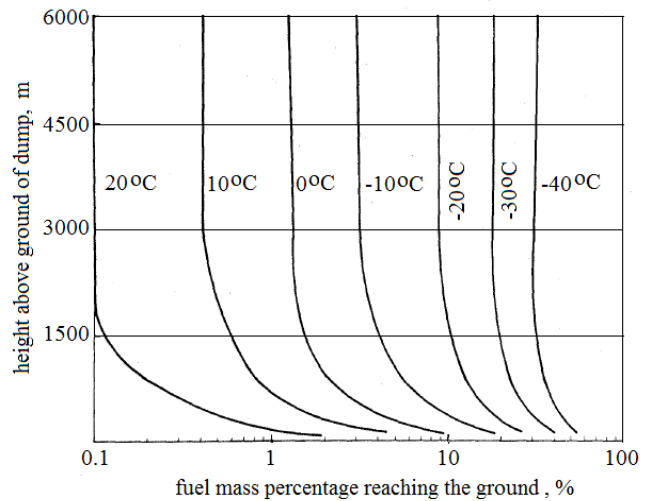

Fig. 46. Percentage of JP-4 liquid fuel drops predicted to reach the ground as a function of dump altitude and ground temperature [37].

Fuel dumped from very low altitude leaves spills on the ground beneath the airplane's flight path and can cause environmental and health hazard. Other factor than temperature, such as:

- fuel jettison nozzle dispersion characteristics;
 - speed of aircraft;
 - humidity;
 - air pressure
- can also affect the amount of fuel that reaches the ground.

APPENDIX D. FAILURE OF D-30KU ENGINE AND CRASH OF IL-62M PASSENGER AIRCRAFT IN WARSAW ON MAY 9, 1987

The failure of the D-30KU turboprop engine was a direct cause of the crash of the IL-62M passenger aircraft in the Forest of Kabaty, Warsaw on May 9, 1987 [35]. The IL-62 was equipped with the same Soloviev D-30KU turboprop engines as the Tu-154M.

The weakness of construction of the D-30KU engine is the inter-shaft bearing joint between the shaft of the low-pressure turbine (LPT) and the shaft of the compressor fan (Fig. 47). This joint is difficult to access and to provide suitable sealing and intensive oil cooling. In this bearing the Russians removed every second roller (13 rollers out of 26) in the cage and drilled 3 holes in the inner race in order to create oil ducts [35].

Direct examination of subsystems of the dismantled engine No 2 and its parts has allowed for the unequivocal statement: *The reason of failure was spreading dynamic damage of the inter shaft roller bearing joint.* The investigating team has found the following (Fig. 48) [35]:

- rollers flat worn and blue tinged as a result of excessive temperature of one side of the cylindrical contact surface with bearing races;
- a fatigue peeling of the contact surface with rollers on the edges of the holes in the inner race of bearing;
- abrasion of the outer race of bearing at about one third of the circumference and maximum depth of more than 1 mm;

- worn tops of comb-type protrusions at labyrinth bushing with tinged surfaces as a result of high temperature.

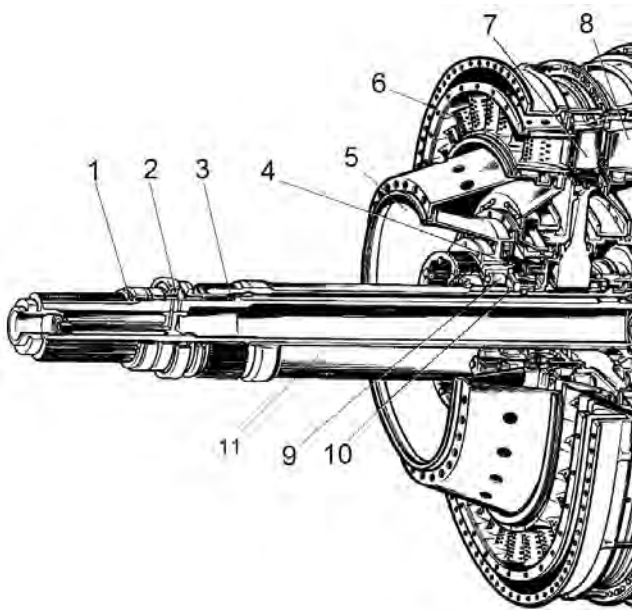

Fig. 47 Portion of turbine of the DK-30KU turbofan engine: 1, 3, 10 - adjustment ring, 2 - inter-shaft bearing, 4 - support bracket of the high pressure turbine (HPT), 5 - eccentric adjustment ring, 6 - inlet guide vane (IGV) for the HPT, 7 - rotor of the 1st stage of the HPT, 8 - 2nd stage vanes, 9 - 3rd stage vanes, 11 - shaft of the rotor of the LPT.

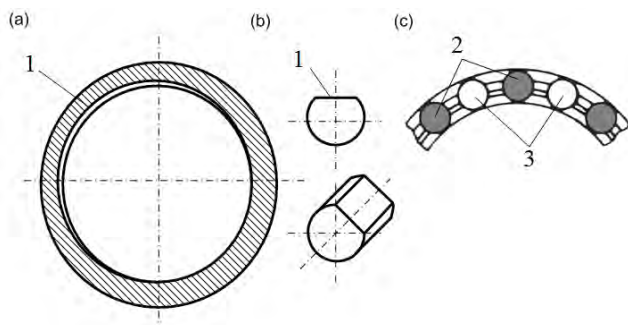

Fig. 48. Destruction of inter-shaft bearing (part 2 in Fig. 47): (a) outer race of bearing, (b) roller of bearing, (c) cage with incomplete rollers. 1 - wear of material, 2 - rollers, 3 - no rollers.

From now on, the destruction of the joint progressed rapidly: the wear of the inner surface of the shaft of the high pressure turbine (HPT) rotor resulted in excessive heat generation. The sleeve, while warming up, expanded and increased friction resulted in the increase of heat production (temperature over 1000°C). This heat, transferred mainly to the shaft of the LPT, warmed up this shaft to a temperature at which the level of torsional stresses has exceeded the permissible value.

The torque of the LPT transferred to the fan rotor had caused the shaft to brake down [35] and the turbine itself broke into several pieces under action of centrifugal forces. Its fragments got into the rear of the engine No 2, where they pierced the shield separating the high and low pressure systems. The explosion was initiated as a result of an immediate balance of pressures and fuel-air mixture, which pulled the entire turbine together with the shaft out of the engine housing. The hot parts of the turbine swirled in all directions at a speed of several hundred meters per second.

One of the pieces damaged the left, adjacent engine No 1, while another pierced the fuselage, causing rapid decompression of the cabin and the cockpit and cut everything encountered along its way and finally stuck in the freight hold No 4 causing a fire.

References

- [1] *Final Report on results of investigation of aviation accident involving the Tu-154B-2, tail number RA-85588, airport Surgut, on January 1, 2011*, (in Russian), Interstate Aviation Committee (MAK), Moscow, available at www.mak.ru/russian/investigations/2011/report_ra-85588.pdf
- [2] *Aeroflot accidents and incidents in the 1970s*, March 1973, Kiev, available from http://en.wikipedia.org/wiki/Aeroflot_accidents_and_incidents_in_the_1970s also <http://www.aero-news.ru/katastrofa-tu-154/>
- [3] *Aircraft Crashes Record Office*, Bureau d'Archives des Accidents Aeronautiques, available at <http://www.baaa-acro.com>
- [4] *Aviation Safety Network (ASN)*, available at <http://aviation-safety.net>
- [5] [4] *Aviation Safety Network (ASN), Accidents and incidents data base for Tu-154 aircraft*, available at <http://aviation-safety.net/database/types/Tupolev-154/index>
- [6] *Investigation Report AX001-1-2/02*, German Federal Bureau of Aircraft Accident Investigations (BFU), Braunschweig, May 2004, available at www.skybrary.aero/bookshelf/books/414.pdf
- [7] *Final Report on the investigation of air accident involving the Tu-154M, tail number RA-85744, airport Domodedovo, on December 04, 2010* (in Russian), Interstate Aviation Committee (MAK), Moscow, available at www.mak.ru/russian/investigations/2010/report_ra-85744.pdf
- [8] *The lucky Tu-154*, English Russia, February 27, 2011, available at <http://englishrussia.com/2011/11/04/the-lucky-tu-154/#more-74596>
- [9] J.F. Gieras, *Selected technical aspects of Tu-154M Smolensk air crash on April 10, 2010*, Mathematical and Computational Forestry and Natural-Resource Sciences, vol. 5, issue 1, 2013, pp. 38-70, available at <http://mcfns.com>
- [10] J.F. Gieras, *Electric power system of Tu-154M passenger aircraft*, *Przegląd Elektrotechniczny* (Electrical Review), vol. 89, No 2a, February 2013, pp. 300-307. available at <http://www.red.pe.org.pl/articles/2013/2a/70.pdf>
- [11] D. Komissarow, *Tupolev Tu-154. The USSR's Medium Range Jet Airliner*, Publishing, Hinckley, UK, 2007.
- [12] *Final Report on the investigation of air accident of Tu154M registration number 101 of the Republic of Poland*, Moscow, 2011, Interstate Aviation Committee (MAK). Moscow, available at http://www.mak.ru/russian/investigations/2010/tu-154m_101/finalreport_eng.pdf
- [13] *Final Report on the examination of the aviation accident no 192/2010/11 involving the Tu-154M airplane, tail number 101, which occurred on April 10th, 2010 in the area of the Smolensk North airfield*,

- Committee for Investigation of National Aviation Accidents, in Polish, Warsaw, 2011, available at <http://mswia.datacenter-poland.pl/FinalReportTu-154M.pdf>
- [14] M. Baker, J. Winn, S. Harris, N. Harrison, *Evidence of explosive damage to materials and structures in air crash investigations*, Chapter 8, pp. 303-347, in *Forensic investigation of explosion*, editor A. Beveridge, 2nd ed., Taylor & Francis, CRC Press, Boca Raton - Lodon - New York, 2012.
- [15] A. Beveridge (editor), *Forensic investigation of explosion*, 2nd ed., Taylor & Francis, CRC Press, Boca Raton - Lodon - New York, 2012.
- [16] W.K. Binienda, *Analiza dynamiczna zniszczenia struktury samolotu Tu-154M w Smolensku 10 kwietnia 2010 roku (Dynamic analysis of destruction of structure of the Tu-154M aircraft in Smolensk on April 10, 2010)*, Proceedings of the 1st Smolensk Conference, Warsaw, 2013, pp. 147-154, available at <http://www.konferencja.home.pl/materialy/04.pdf>
- [17] H. Garstang, *Aircraft explosive sabotage investigation*, Chapter 7, pp. 197-302, in *Forensic investigation of explosion*, editor A. Beveridge, 2nd ed., Taylor & Francis, CRC Press, Boca Raton - Lodon - New York, 2012.
- [18] G.A. Jorgensen, *Additional aspects of the Smolensk air crash*, 2013, available at <http://orka.sejm.gov.pl>
- [19] A. Kotzakolios, *Blast response of aircraft structures*, PhD thesis, Dept of Mechanical Eng and Aeronautics, University of Patras, Greece, available at [http://nemertes.lis.upatras.gr/jspui/bitstream/10889/5068/3/Nimertis_Kotzakolios\(aer\).pdf](http://nemertes.lis.upatras.gr/jspui/bitstream/10889/5068/3/Nimertis_Kotzakolios(aer).pdf)
- [20] M. Mirzei, *Finite element analysis of deformation and fracture of cylindrical tubes under internal moving pressures*, in "Finite Element Analysis", edited by D. Morata, Scio, 2010, pp. 479-500, available at <http://www.intechopen.com>
- [21] Y.I. Moon, G. Bharatram, S.A. Schimmels, V.B. Venkkayya, *A vulnerability map of a commecrial acircraft*, Wright Patterson AFB, OH, USA, available at <http://citeseerx.ist.psu.edu>
- [22] K. Nowaczyk, *Trotyl - wyniki pierwszego testu (Trotyl - the results of the first test)*, November 2, 2012, available at <http://naszeblogi.pl/33530-trotyl-wyniki-pierwszego-testu>
- [23] J.B. Obrebski, *Opis sposobu zniszczenia malego fragmentu samolotu Tu-154M Nr 101 (Description of mechanism of destruction of a small fragment of the Tu-154M No 101 aircraft)*, Proceedings of the 1st Smolensk Conference, Warsaw, 2013, pp. 87-96, available at <http://www.konferencja.home.pl/materialy/10.pdf>
- [24] C.M. Wentzel, R.M. van de Kastele, F. Soetens, *Investigation of vulerability of aircraft structure and materials towards cabin explosions*, Paper No. 48, 1st Int. Conf. on Damage Tolerance of Aircraft Structures DTAS'07, Delft, The Netherlands, 2007, available at <http://dtas2007.fyper.com/>
- [25] P. Witakowski, *Mechanizm zniszczenia w wybranych katastrofach lotniczych (Mechanism of destruction in selected air crashes)*, Proceedings of the 1st Smolensk Conference, Warsaw, 2013, pp. 35-54, available at <http://www.konferencja.home.pl/materialy/04.pdf>
- [26] C. Zhang, W. K. Binienda, F. E. Horvat, W. Wang, *Application of numerical methods for crashworthiness investigation of a large aircraft wing impact with a tree*, Mathematical and Computational Forestry and Natural-Resource Sciences, vol. 5, issue 1, 2013, pp. 71-85, available at <http://mcfns.com>
- [27] J.F. Gieras, *Electrical ignition of fuel-air mixture in aircraft fuel tanks*, Przegląd Elektrotechniczny (Electrical Review), vol. 89, No 7, July 2013, pp. 17-24, available at <http://www.red.pe.org.pl/articles/2013/7/5.pdf>
- [28] T.W. Chao, *Gaseous detonation-driven fracture of tubes*, PhD Thesis, California institute of of Technology, Pasadena, CA, USA, available at <http://thesis.library.caltech.edu/1726>
- [29] A. Dacko, J. Toczynski, *Structural response of a blast loaded fuselage*, Journal of KONES Powertrain and Transport, vol. 17, No. 1, 2010, pp.101-109, available at http://ilot.edu.pl/kones/2010/1_2010/2010_dacko_toczynski_structural.pdf
- [30] A. Dacko, J. Toczynski, *Blast response of a thin-walled aircraft structure*, CMM-2011, Computer Methods in Mechanics, Warsaw, 2011, available at <http://www.cmm.il.pw.edu.pl/cd/pdf/284.pdf>
- [31] *Flight technology and its utilization*. Annexure Nr 4 to Final Report [15], Warsaw, 2011.
- [32] W. Jagielski, *Busting the lord of war*, Eastonline, No 33, December 2010, pp. 56-61, available at <http://www.eastonline.eu/en/east-33/692-ecco-la-vera-storia-di-lord-of-war>
- [33] K. Gojska-Hejke, D. Kania, *W pierwszym opisie miejsca katastrofy nie ma panczernej brzozy (The first description of the crash site does not mention armorous birch tree)* Nowe Panstwo (New State), No. 1, 2013, p. 20, available at <http://www.panstwo.net>
- [34] S. Szczecinski, *Awaria silnika NK-8 bedaca bezposrednia przyczyna katastrofy samolotu IL-62 w dniu 14 marca 1980 roku na Okeciu (Failure of the NK-8 engine as a direct cause of the IL-62 aircraft crash on March 14, 1980 at Okecie)*, Prace Instytutu Lotnictwa Nr 199, Warszawa, 2009, pp. 158-160, available at http://ilot.edu.pl/wp-content/uploads/2011/03/PIL_199.pdf
- [35] S. Szczecinski, *Awaria silnika D-30KU bedaca bezposrednia przyczyna katastrofy samolotu IL-62M w dniu 09 maja 1987 roku w Lesie Kabackim (Failure of the D-30KU engine as a direct cause of the IL-62 aircraft crash on May 9, 1987 at Kabaty Forest)*, Prace Instytutu Lotnictwa Nr 199, Warszawa, 2009, pp. 161-164, available at http://ilot.edu.pl/wp-content/uploads/2011/03/PIL_199.pdf
- [36] R. Colella, *Overweight landing. Fuel jettison. What to consider*, Aero Quarterly, Qtr 03/07, pp. 14-20.
- [37] R.E. Good, H.J. Clevel, *Drop formation and evaporation of JP-4 fuel jettisoned from aircraft*, Journal of Aircraft, vol. 17, no 7, July 1980, pp. 450-456.